

Set to 100 or 0 with just one button!
 **neo PRESET**



Accurate, Stable Operation
meets Simple Setup!



Laser sensor **NEW**
LV-neo



Fiberoptic sensor **NEW Version**
FS-neo



Photoelectric sensor **NEW**
PS-neo

The technology first introduced by the FS NEO to make easy setup and simple display a reality is now available in the LV and PS Series!



Simple Setup

1 push setting with the PRESET Button

Simple Display

All sensors display "0" or "100"

Simple Operation

Laser, fiberoptic, and photoelectric models all share the same simple functionality



Simple and Precise detection with the “NEO Preset”

**NEW
CONCEPT**

Complete setting with just one click

When using a thru-beam model, sensitivity adjustments are completed with a single push of the PRESET button. Using a reflective model? Press once with a target present, and once without to calibrate according to the different conditions.



**NEW
CONCEPT**

Simple one click setup for reflective applications

When using diffuse reflective type sensors, variations in the received light intensity can occur due to changing conditions such as mounting position and target configuration, thus resulting in unstable operation when attempting to detect small objects. The NEO Preset function erases these concerns and enables detection to be as simple as a thru-beam.

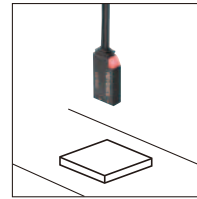

No target present...

100



Target detected!

0



With the "NEO Series", sensor changes never go undetected!

Conventional

If a sensor error occurs...

It is difficult to know which sensor has the error.



NEO Preset

If a sensor error occurs...

The error is quickly noticed!



By standardizing the received light intensity display of multiple sensors to "100" and "0", it is easy to tell where an error has occurred because the sensor will not return to the original display value of "100" or "0".

**NEW
CONCEPT**

Laser, fiberoptic, and photoelectric models all share the same simple operation

Until now, the method of operation to activate new features differed from sensor to sensor. The NEO Series eliminates this problem by integrating the same features, functions, and key layout in all series. This allows you to select the best model for your application without having to learn the operation of a new sensor each time.



neo series

Digital Laser Sensor

LV-neo

Long distance with a visible beam for the next level of laser detection

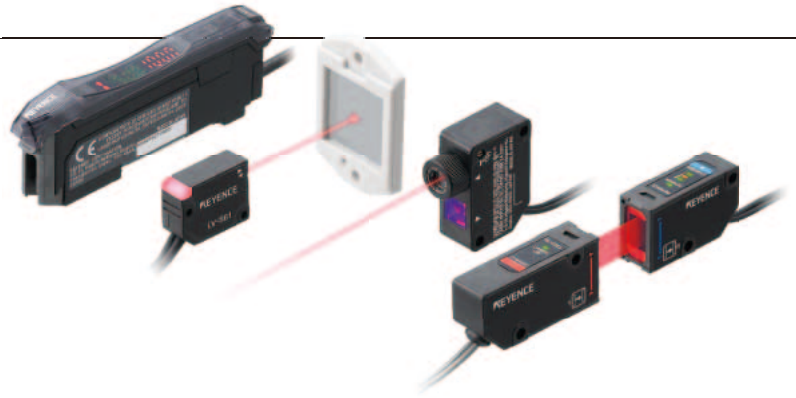

Digital Fiberoptic Sensor

FS-neo&FU

More than 100 fiber unit variations to support a wide range of applications

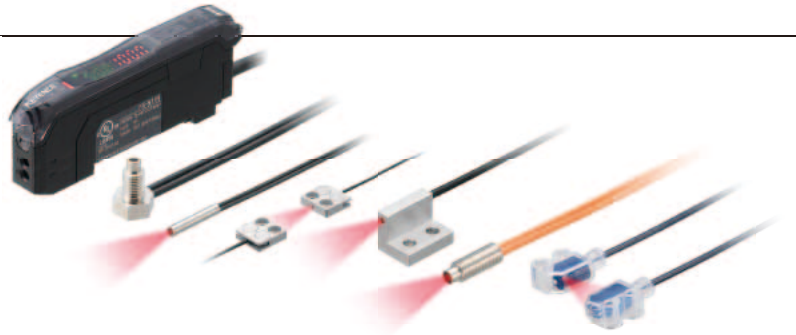

Digital Photoelectric Sensor

PS-neo

High environmental resistance and cable extension capabilities provide increased installation versatility

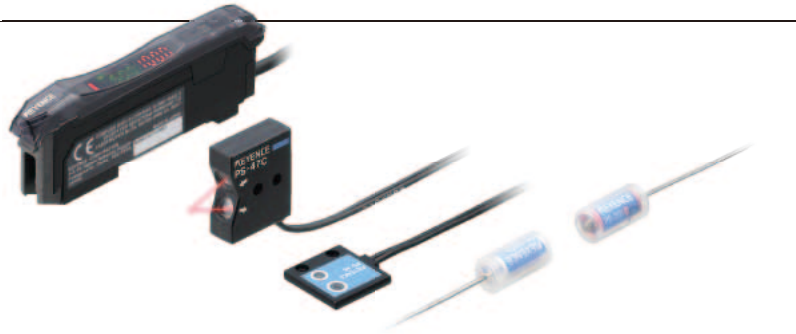

Network Communication Unit

NU series

Incorporate the NEO Series with an open field network for complete interfacing versatility

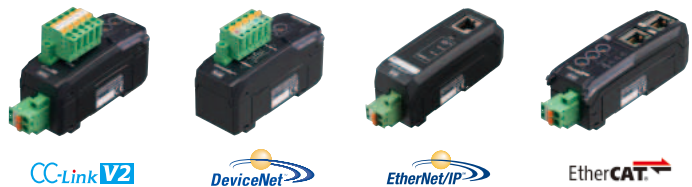

Want to see the detection position	A	Since the spot is a visible red laser, the detection point is easy to see, even at long distances.
Want to prevent detection errors caused by light wraparound	A	Narrow laser spot remains unchanged over long range.
Want to increase the installation distance	A	Detection spot size remains unchanged as the detection distance is increased.
Need to use in a harsh environment	B	
Need to detect small targets	A	
Want to adjust the sensor beam spot size	A	Using the LV-NH32, the beam spot can be adjusted to a focused or wide spot, regardless of the mounting distance.
Need to detect fast-moving targets	A	80 μs response time in HIGH SPEED mode.
Need an extended sensor head cable	B	Sensor head cable can be extended up to 10 m (3.28').
Limited installation space	B	Variety of small size sensor heads. In addition, increased detection distance reduces installation limitations.
		P.8 ▶
	C	Visible red LED enables the spot to be seen at closer distances
	B	
	A	A wide variety of heat resistant and fluorocarbon polymer encased sensor heads provide durable options for harsh environments.
	B	Beam spot adjustment is possible when using the FU-10 or F-5HA. (Mounting distance must remain unchanged.)
	A	50 μs response time in HIGH SPEED mode.
	A	Wide variety of small sensor head shapes and sizes allow for installation in almost any space-limited application.
		P.24 ▶
	C	
	B	Several fluorocarbon polymer encased sensor heads provide durable options for water, oil, and chemical environments.
	C	PS-49 can detect targets as small as ø1.5 mm (0.06") at a distance of 50 mm (1.97').
	B	Sensor head cable can be extended up to 10 m (3.28').
	C	
		P.54 ▶
Want uniform control of multiple sensors		
Want to reduce wiring		
		P.62 ▶

A : Excellent
 B : Good
 C : Acceptable

Long distance with a visible beam
 for the next level of laser detection



* The UL certificate is for LV-NHxx sensor head and LV-Nxx amplifier used in combination.

Using a laser enables long distance detection for difficult applications while maintaining a focused, visible beam spot.

1 Visible red laser beam spot

Precise detection positioning is possible without troublesome installation alignment caused by a weak or invisible beam.

2 Long distance detection with a focused beam

By using a laser light source, the beam spot remains unchanged over long distances, eliminating any concern about the mounting location.

3 Full lineup conforming to Class 1 laser requirements

Class 1 lasers provide completely safe operation and can be used in the same manner as other photoelectric sensors.

LV-NEO FUNCTION

NEO Preset

Simply press the PRESET button to change the light intensity display to "100" or "0" to complete the sensitivity settings.

NEO MEGA

MEGA Mode provides Class 2 equivalent light intensity while maintaining Class 1 laser safety.

Built-in application modes

DATUM function

Even if dirt or debris causes the displayed light intensity to decrease, the DATUM function automatically detects the change and restores the display to its original state, thus maintaining stable operation.

Open field network compatibility

Connect an NU Series model for open field network compatibility.

Reduced wiring

No need to wire to a terminal block when using the NU Series.

Interference prevention function

Pause function

Sleep function

Monitor Output Type (LV-N11MN)

Lasers are Visible, Long Range, and Adjustable

Visible beam ensures simple alignment and installation

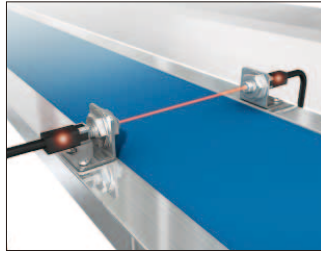

Long range detection is possible, eliminating installation restrictions

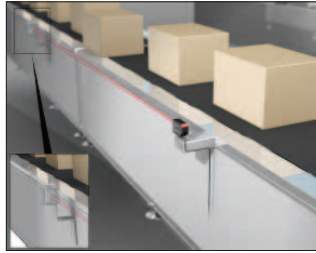

Because the beam remains unchanged, lasers can easily detect through small gaps

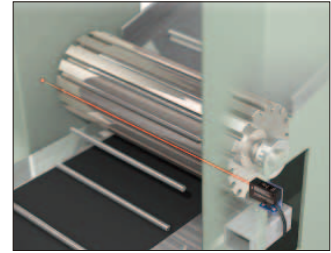

Stable detection of small targets

Because the beam remains focused, small targets can be pinpointed for detection. Furthermore, because the LV-NEO resists up to 20,000 lux, stable operation is maintained even when exposed to sun and fluorescent lighting.

Conventional photoelectric sensor

Because the light diffuses, the sensor is affected by background objects.

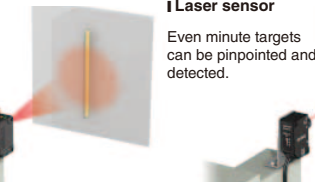

Laser sensor

Even minute targets can be pinpointed and detected.

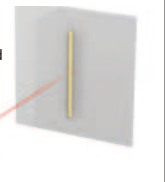

Built-in application modes enable easy selection of desired functions

Laser sensors are designed for general use, but requirements for target detection often demand more. Therefore, customers often seek additional setting options. The following modes are built into the NEO Series. Simply select the intended use. There is no need for complicated setting operations.



Drop detection mode

Targets dropped through the beam are detected by the falling intensity level.



Percentage tuning mode

The set value is tuned and maintained to -5% of the current value.



Reflective model background cancellation mode

Sets the background as 0 with no target present when using a reflective model.



Maximum intensity mode

Sets the sensor to MEGA mode with the extended 5-digit display activated.



Area detection mode

Set a high and low value for zone detection.



Zero datum mode

Sets the condition of no target present as 0 to allow simple detection of transparent objects or height changes.

Interference Prevention function supports up to 8 sensors*

Factory automation equipment is continuously decreasing in size, yet the number of applications that require sensors is steadily rising. When installing multiple sensors in a small area, the problem of interference between nearby sensors can arise. The NEO Series is equipped with a function that prevents interference from up to 4 (or 8*) other sensors. * When in ULTRA or MEGA mode and set to "double".

I Sensor transmission cycle timing

Interference is prevented by automatically shifting the radiation cycle pattern of the laser light.

* Diagram represents LV-N11N / N12N when using FINE mode and set to double.
* Same operation concept as the FS-N and PS-N.

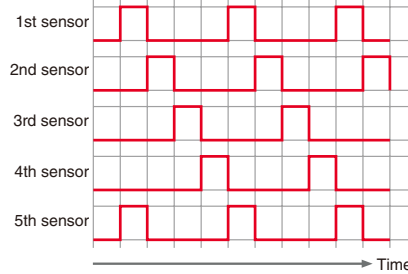

Pause function controls the sensor output

The desired sensor output status can be controlled through an external signal input, regardless of the received light intensity. This will prove useful during a test run because the ON/OFF signal from the sensor can be confirmed on the PLC without requiring the sensor to have a target present/absent.

<Application improvement example using the area laser>

LV-NH300 30 mm (1.18")-wide area type (Thrubeam model)

Less sensors are required to provide the same area detection



8 fiberoptic sensors used

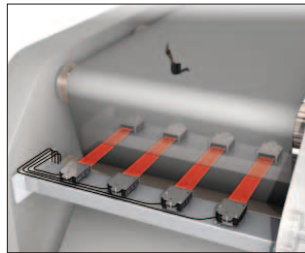

4 LV-NH300 sensors used

I Detection of a hole in the target (hole position unspecified) <Film tear detection>

The LV-NH300 is a 30 mm (1.18") wide directional laser sensor. Holes within the 30 mm (1.18") width are reliably detected. Because the detection area is small when using other photoelectric sensors, they may be unable to reliably detect the holes if the position varies. As a result, multiple sensors are required with the conventional method.

LV-NH42 Long distance area type (Reflective model)

Variation in target position is possible

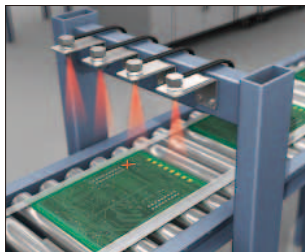

4 fiberoptic sensors used

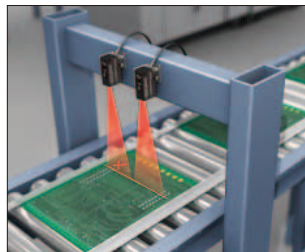

2 LV-NH42 sensors used

I Mark detection with variable target position <Board BAT mark detection>

With the LV-NH42 area reflective laser sensor, the detection area increases as the detection distance increases. If the target is within the area range, the sensor will detect even if there is position variation. As a result, the number of required sensors can be reduced. In addition, the detection area is easily confirmed due to the visible laser beam.

<Sensor head variations>

LV-NH32 Adjustable Beam Spot

Spot size can be adjusted as needed



When using the LV-NH32, simply rotate the focus ring to change the spot diameter/width as desired, according to the size of the target. Additionally, the use of a very high-powered sensor head enables detection over long distances of up to 1.2 m (3.94').

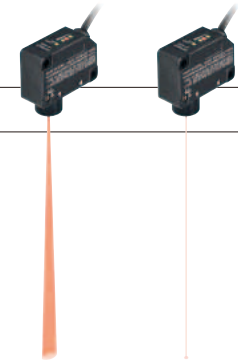

LV-NH35 / NH62 / S61 Coaxial Structure

Coaxial light ensures detection through small spaces

When using general reflective type photoelectric sensors, the position at which the sensor switches ON when the target passes through may vary. Additionally, general sensors cannot always be installed if the installation area is too small. This problem can be solved by using a coaxial structure in which the receiver is positioned in the same axis as the transmitter.

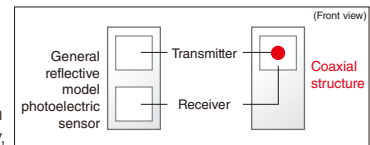

I General reflective photoelectric sensor

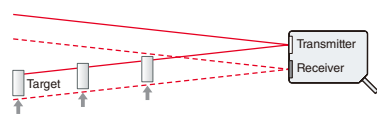

I Coaxial structure

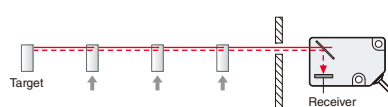

Even in small locations, the target can be detected as long as the beam spot is able to reach the target. The sensor switches ON at the same position, regardless of the distance to the target.

LV-S71 / S72 Compact, M6 Thrubeam

Compact thrubeam installation is now possible

Featuring an ultra-small M6 size sensor head, installation area is no longer a concern. A variety of installation brackets are also available.

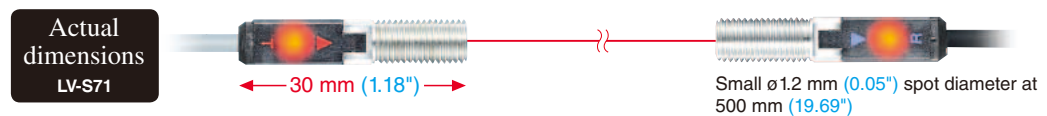

LV-S62 / S63 Multi-Wavelength Laser

Stable transparent target detection using a multi-wavelength laser

A multi-wavelength laser has been adopted to ensure stable, accurate detection of transparent targets.

I Single wavelength

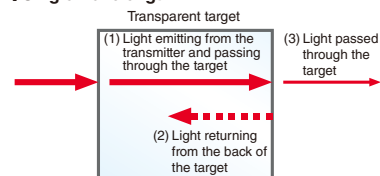

I Multiple wavelengths

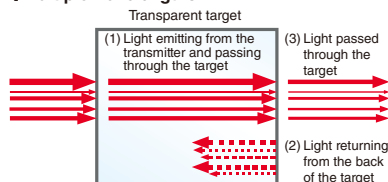

At a single wavelength, the light is reduced by surfaces (1) and (2), causing the light at (3) to be unstable. By emitting light at different wavelengths, the effects of surface (2) on the light are kept to a minimum, enabling the light intensity at (3) to remain stable.

Reflective ▲ P.13	Spot type	 <p>LV-S41</p> <p>Small size</p> <p>Enables long distance, small spot detection with an ultra-small footprint.</p>	 <p>LV-S41L</p> <p>Small size, Side view</p> <p>Space-saving, side view sensor head provides a long distance small spot.</p>	 <p>LV-NH32 <small>NEW</small></p> <p>Adjustable beam spot</p> <p>Up to 1.2 m 3.9' detecting distance. Freely adjust the size and shape of the beam spot for precision and versatility.</p>		
		 <p>LV-NH35 <small>NEW</small></p> <p>Coaxial structure</p> <p>Provides effective detection through a small hole or narrow gap.</p>	 <p>LV-NH37 <small>NEW</small></p> <p>Ultra-small beam spot $\phi 50 \mu\text{m}$ $\phi 1.97 \text{ Mil}$</p> <p>Enables extremely minute target detection with background cancellation.</p>	 <p>LV-S31</p> <p>Small size, Adjustable range</p> <p>Dual photodiode allows adjustable distance-based detection while reducing background influence.</p>		
		Area type	 <p>LV-NH42 <small>NEW</small></p> <p>Long distance</p> <p>Reliably detects targets with holes or position variation.</p>			
	Retro-reflective ▲ P.14	Spot type	 <p>LV-S61</p> <p>Small beam spot</p> <p>Provides compact size while achieving a small beam spot of $\phi 2.5 \text{ mm } \phi 0.1''$ for up to 500 mm 19.69' distance.</p>	 <p>LV-NH62 <small>NEW</small></p> <p>Standard</p> <p>Achieves a small beam spot of $\phi 1.5 \text{ mm } \phi 0.06''$ over a 1 m 3.3' range with the capability to detect up to 8 m 26.2'.</p>		
			Area type	 <p>LV-S62</p> <p>Area beam</p> <p>Excellent transparent target detection with the ability to switch between a small spot or area beam.</p>	 <p>LV-S63</p> <p>Long-distance transparent object detection</p> <p>35 m 114.8' detection with a square beam spot to provide stable detection of transparent objects.</p>	
		Spot type	 <p>LV-S71</p> <p>Small: M6</p> <p>Provides the compact size of a fiber sensor while achieving a small beam spot of $\phi 1.2 \text{ mm } \phi 0.05''$ at a distance of 500 mm 19.69'.</p>	 <p>LV-S72</p> <p>Small: M6 (with slit)</p> <p>Built-in $\phi 6 \text{ mm } \phi 0.24''$ slit filter allows for high accuracy detection.</p>		
Thru-beam ▲ P.15	Area type	 <p>LV-NH100 <small>NEW</small></p> <p>10 mm 0.39" beam width</p> <p>Effective for height differentiation and applications with position variation.</p>	 <p>LV-NH300 <small>NEW</small></p> <p>30 mm 1.18" beam width</p> <p>Effective for height differentiation and applications with position variation.</p>	 <p>LV-NH110 <small>NEW</small></p> <p>High power 10 mm 0.39" beam width</p> <p>High power enables accurate detection of low light transmission targets.</p>		
		Amplifier part ▲ P.17	 <p>Cable Type <small>NEW</small></p>	 <p>M8 connector Type <small>NEW</small></p>	 <p>Zero line Type <small>NEW</small></p>	 <p>Monitor output Type <small>NEW</small></p>

Reflective model Spot type

Type	Appearance (mm inch)	Detecting distance (mm inch)	Spot diameter (mm inch)	Model	Dimensions
Small size		MEGA : 600 23.62" ULTRA : 500 19.69" SUPER : 400 15.75" TURBO : 300 11.81" FINE : 200 7.87" HSP : 150 5.91"	Approx. $\phi 1.2 \phi 0.05^*$ (Up to 500 mm 19.69" distance)	LV-S41	[P.18]
Small size, Side view		MEGA : 480 18.9" ULTRA : 400 15.75" SUPER : 320 12.6" TURBO : 240 9.45" FINE : 160 6.30" HSP : 120 4.72"	Approx. $\phi 1.2 \phi 0.05^*$ (Up to 400 mm 15.75" distance)	LV-S41L	[P.18]
Adjustable beam spot		MEGA : 1200 47.24" ULTRA : 1000 39.37" SUPER : 750 29.53" TURBO : 500 19.69" FINE : 250 9.84" HSP : 200 7.87"	Approx. $\phi 0.8 \phi 0.03^*$ max. (Up to 300 mm 11.81" distance)	LV-NH32 NEW	[P.20]
Coaxial structure		MEGA : 750 29.53" ULTRA : 600 23.62" SUPER : 450 17.72" TURBO : 300 11.81" FINE : 150 5.91" HSP : 100 3.94"	Approx. $\phi 2 \phi 0.08^*$ (Up to 600 mm 23.62" distance)	LV-NH35 NEW	[P.21]
Ultra-small beam spot		70±15 2.76±0.59" (Common for all power modes)	Approx. $\phi 50 \mu\text{m} \phi 1.97 \text{ Mil}$ (At 70 mm 2.76" distance)	LV-NH37 NEW	[P.21]
Small size, Adjustable range		Adjustment range: 50 to 200 1.97" to 7.87" (Range in which the reference distance can be adjusted)	Approx. $\phi 2 \phi 0.08^*$ (Up to 200 mm 7.87" distance)	LV-S31	[P.18]

Reflective model Area type

Type	Appearance (mm inch)	Detecting distance (mm inch)	Area width (mm inch)	Model	Dimensions
Long distance		MEGA : 1200 47.24" ULTRA : 1000 39.37" SUPER : 750 29.53" TURBO : 500 19.69" FINE : 250 9.84" HSP : 200 7.87"	Approx. 48x0.4 1.89" x 0.02" (At 200 mm 7.87" distance)	LV-NH42 NEW	[P.21]

Accessories/Options

LV-S41

With mounting bracket
L-shaped mounting bracket OP-66846*
Accessory

LV-S41L

With mounting bracket
L-shaped mounting bracket OP-66846*
Accessory (front mounted)
Accessory (rear mounted)

LV-NH32

With mounting bracket (accessory)

LV-NH35

With mounting bracket (accessory)

LV-NH37

With mounting bracket (accessory)

LV-S31

With mounting bracket (accessory)

LV-NH42

With mounting bracket (accessory)

Slit (accessory)

Area width can be selected.

Lens LV-L01* [P.16]

For thicker area.

* sold separately

Reflective model characteristics

LV-NH32

Characteristics of detecting distance and minimum spot diameter (typical example)

Distance (mm)	Distance (inch)	Spot diameter (mm)	Spot diameter (inch)
100	3.94"	0.004"	0.0004"
200	7.87"	0.008"	0.0008"
300	11.81"	0.012"	0.0012"
400	15.75"	0.016"	0.0016"

LV-NH37

Characteristics of setting distance and spot diameter (typical example)

Distance (mm)	Distance (inch)	Spot diameter (mm)	Spot diameter (Mil)
35	1.38"	3.94	15.75
45	1.77"	2.17	8.54
55	2.17"	2.56	10.08
65	2.56"	2.95	11.61
75	2.95"	3.35	13.19
85	3.35"	3.74	14.72
95	3.74"	4.13	16.25
105	4.13"	4.52	17.81

LV-NH42

Characteristics of detecting distance and area width (typical example)

Distance (mm)	Distance (inch)	Area width (mm)	Area width (inch)
100	3.94"	0.79"	0.031"
200	7.87"	1.57"	0.062"
300	11.81"	2.36"	0.093"
400	15.75"	3.15"	0.124"
500	19.69"	3.94"	0.155"

Retro-reflective Type

Spot type

Type	Appearance (mm inch)	Detecting distance (m feet)	Spot diameter (mm inch)	Model	Dimensions
Small beam spot		MEGA : 2.5 8.2' ULTRA : 2 6.6' SUPER : 1.5 4.9' TURBO : 1 3.3' FINE : 0.75 2.5' HSP : 0.5 1.6'	Approx. ϕ 2.5 ϕ 0.10" (Up to 0.5 m 1.6' distance)	LV-S61	[P.18]
Standard		MEGA : 8 26.2' ULTRA : 7 23' SUPER : 6 19.7' TURBO : 5 16.4' FINE : 3.5 11.5' HSP : 2 6.6'	Approx. ϕ 1.5 ϕ 0.06" (Up to 1 m 3.3' distance)	LV-NH62 NEW	[P.21]

All models support the P.R.O. function. The polarizing filter reduces direct reflected light from a mirrored-surface workpiece.

Retro-reflective Type

Area type

Type	Appearance (mm)	Detecting distance (m feet)	Area width (mm inch)	Model	Dimensions
Wide area		MEGA : 12(8) 39.4(19.7) ^{*1} ULTRA : 10(5) 32.8(16.4) SUPER : 8(3.5) 26.2(11.5) TURBO : 5(2) 16.4(6.6) FINE : 2.5(0.7) 8.2(2.3)	Area spot: Approx. 10x2 mm 0.39"x0.08" Small beam spot: Approx. 2x2 mm 0.08"x0.08" (Up to 500 mm 19.69" distance)	LV-S62	[P.18]
Long-distance transparent object detection		MEGA : 35 114.8 ^{*2} ULTRA : 30 98.4' SUPER : 25 82' TURBO : 15 49.2' FINE : 8 26.2'	Approx. 8x12 mm 0.31"x0.47" (Up to 3.5 m 11.5' distance)	LV-S63	[P.19]

All models support the P.R.O. function. The polarizing filter reduces direct reflected light from a mirrored-surface workpiece. *1 Numbers not enclosed in parentheses are the detecting distance for area spot. Numbers enclosed in parentheses are the detecting distance for small beam spot. To be used for glass detection, we recommend that the detecting distance is set to 1 m or less. *2 To be used for glass detection, we recommend that the detecting distance is set to 3.5 m or less.

Mounting bracket (accessories/options)

LV-S61

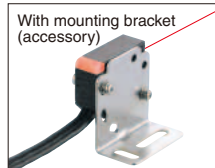

LV-S62 Using the optional mounting brackets allows you to adjust the optical axis right, left, up, or down.

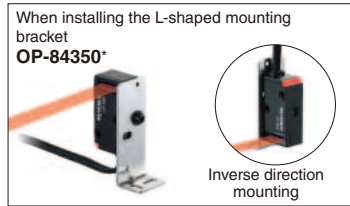

LV-NH62

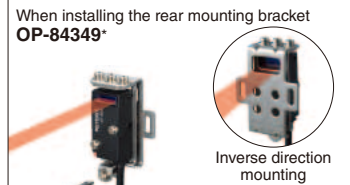
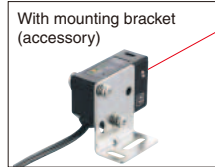

LV-S63

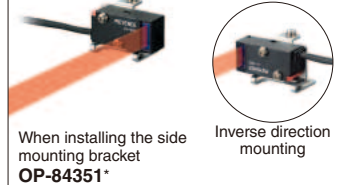
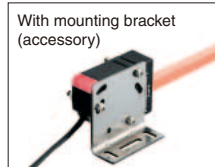

* sold separately

Be sure to use the dedicated mounting brackets because optical axis adjustment is required.

Characteristics

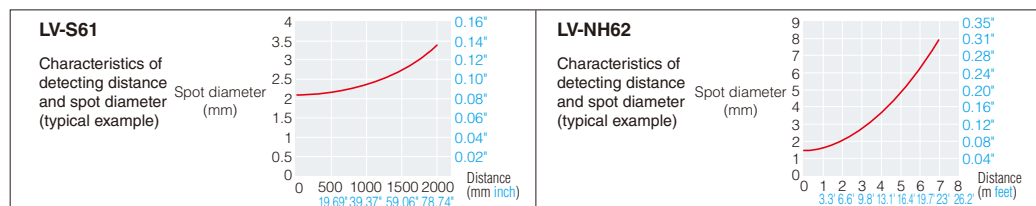

Reflectors

OP-51430 (R-6 Gray) (Included with LV-S61)

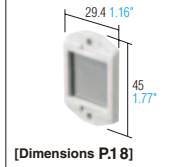

R-6 (Included with LV-NH62)

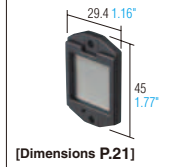

R-7 (Included with LV-NH62)

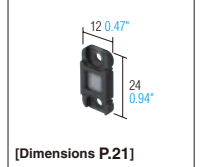

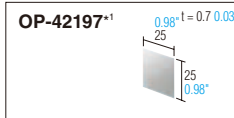

Reflective tape (sold separately)

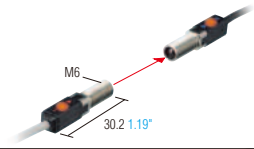

(The detecting distance remains unchanged even if the reflective tape is used.)
*1 Less light intensity variation type (model OP-87123) is also available.

Thrubeam type Spot type

Type	Appearance (mm inch)	Detecting distance (mm inch)	Spot diameter (mm inch)	Model	Dimensions
Small beam spot		500 19.69" (Common for all power modes.)	Approx. $\phi 1.2$ $\phi 0.05$ " (Detecting distance: 500 mm 19.69")	LV-S71	[P.20]
Position detection		500 19.69" (Common for all power modes.)	Approx. $\phi 6$ $\phi 0.24$ " (Detecting distance: 500 mm 19.69")	LV-S72	[P.20]

Thrubeam type Area type

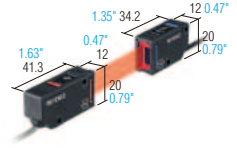
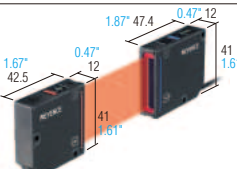
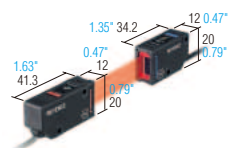
Type	Detecting width (mm)	Appearance (mm inch)	Detecting distance (mm inch)	Area width (mm inch)	Model	Dimensions
Standard	10		2000 78.74" (Common for all power modes.)	Approx. 12 0.47"	LV-NH100 NEW	[P.22]
	30			Approx. 32 1.26"	LV-NH300 NEW	[P.22]
High power	10			Approx. 12 0.47"	LV-NH110 NEW	[P.22]

Mounting bracket (accessories/options)

LV-S71 / S72

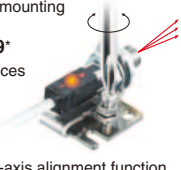
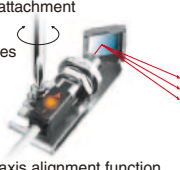
	Standard mounting bracket (accessory)		Small type mounting bracket OP-66869* Set of 2 pieces		Side viewer attachment LV-F1* Set of 2 pieces
			With optical-axis alignment function Optical-axis can be aligned from the upper direction.		With optical-axis alignment function Optical-axis can be aligned from the upper direction.

LV-NH300

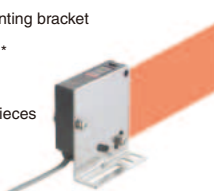
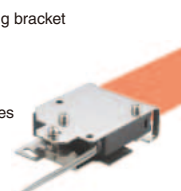
	With mounting bracket LV-B301* Mounted vertically Set of 2 pieces		With mounting bracket LV-B302* Mounted horizontally Set of 2 pieces
---	---	---	---

LV-NH100 / NH110

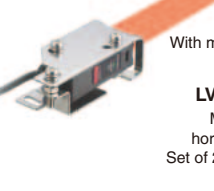
	With mounting bracket LV-B101* Mounted vertically Set of 2 pieces		With mounting bracket LV-B102* Mounted horizontally Set of 2 pieces
--	---	---	---

* sold separately

Sensor head specifications

LV-Sxx (Spot Reflective)

Type	Small	Small side view	Adjustable distance definite reflective
Model	LV-S41	LV-S41L	LV-S31
FDA (CDRH) Part 1040.10	Class 1 Laser Product		
IEC 60825-1	Class 1 Laser Product		
Light source	Visible red semiconductor laser, Wavelength: 655 nm		
Detecting distance	MEGA	600 mm 23.62"	480 mm 18.9"
	ULTRA	500 mm 19.69"	400 mm 15.75"
	SUPER	400 mm 15.75"	320 mm 12.6"
	TURBO	300 mm 11.81"	240 mm 9.45"
	FINE	200 mm 7.87"	160 mm 6.3"
	HSP	150 mm 5.91"	120 mm 4.72"
Ambient temperature	-10 to +50°C (14 to 122°F) (No freezing)		0 to +50°C (32 to 122°F) (No freezing)
Material	Case	Glass reinforced plastic	
	Display	Polycarbonate	
	Lens cover	Norbornene plastic	Acrylic
Weight	Approx. 70 g		Approx. 75 g
Dimensions	[P.18]	[P.18]	[P.18]

* Transmitter lens: Norbornene plastic/Receiver lens cover: Polyarylate

LV-NHxx (Area Beam Reflective)

Type	Long-distance area	
Model	LV-NH42	
FDA (CDRH) Part 1040.10	Class 1 Laser Product	
IEC 60825-1	Class 1 Laser Product	
Light source	Visible red semiconductor laser, Wavelength: 660 nm	
Detecting distance	MEGA	1200 mm 47.24"
	ULTRA	1000 mm 39.37"
	SUPER	750 mm 29.53"
	TURBO	500 mm 19.69"
	FINE	250 mm 9.84"
	HSP	200 mm 7.87"
Ambient temperature	-10 to +55 °C (14 to 131°F) (No freezing)	
Relative humidity	35 to 85% RH (No condensation)	
Material	Case	Glass reinforced plastic
	Lens cover	Polyarylate
Weight	Approx. 65 g	
Dimensions	[P.21]	

LV-Sxx (Spot Thrubeam)

Type	Small standard	Small (with slit)
Model	LV-S71	LV-S72
FDA (CDRH) Part 1040.10	Class 1 Laser Product	
IEC 60825-1	Class 1 Laser Product	
Light source	Visible red semiconductor laser, Wavelength: 655 nm	
Detecting distance	MEGA	
	ULTRA	
	SUPER	500 mm 19.69"
	TURBO	
	FINE	
	HSP	
Ambient temperature	-10 to +50°C (14 to 122°F) (No freezing)	
Material	Metal part: Stainless steel, Plastic part: Polyarylate	
Lens cover	Transmitter: Norbornene plastic	Receiver: Glass
	Transmitter: Polyarylate	Receiver: Norbornene plastic
Weight	Approx. 70 g	
Dimensions	[→P.20]	[→P.20]

LV-L01 Specifications (lens attachment for LV-NH42) (Unit: mm inch)

Name	LV-L01	slit 1 is mounted	slit 2 is mounted	slit 3 is mounted	slit 4 is mounted	
Detecting distance	MEGA	960 37.8"	840 33.07"	720 28.35"	600 23.62"	480 18.9"
	ULTRA	800 31.5"	700 27.56"	600 23.62"	500 19.69"	400 15.75"
	SUPER	600 23.62"	525 20.67"	450 17.72"	375 14.76"	300 11.81"
	TURBO	400 15.75"	350 13.78"	300 11.81"	250 9.84"	200 7.87"
	FINE	200 7.87"	175 6.89"	150 5.91"	125 4.92"	100 3.94"
	HSP	160 6.3"	140 5.51"	120 4.72"	100 3.94"	80 3.15"
Area thickness	50 mm 1.97"	2.6 0.1"				
	100 mm 3.94"	4.0 0.16"				
	150 mm 5.91"	5.5 0.22"				
Area width	50 mm 1.97"	15.0 0.59"	11.5 0.45"	9.5 0.37"	7.5 0.3"	5.5 0.22"
	100 mm 3.94"	26.0 1.02"	20.0 0.79"	17.0 0.67"	13.0 0.51"	10.0 0.39"
	150 mm 5.91"	37.0 1.46"	29.0 1.14"	24.0 0.94"	19.0 0.75"	14.0 0.55"
	Case material	Polyacetal (main body) Arton (lens)				
Weight	Approx. 1 g					
Dimensions	[P.21]					

LV-NHxx (Spot Reflective)

Type	Straight-beam coaxial	Adjustable beam spot	Ultra-small beam spot
Model	LV-NH35	LV-NH32	LV-NH37
FDA (CDRH) Part 1040.10	Class 1 Laser Product		
IEC 60825-1	Class 1 Laser Product		
Light source	Visible red semiconductor laser, Wavelength: 660 nm		
Detecting distance	MEGA	750 mm 29.53"	1200 mm 47.24"
	ULTRA	600 mm 23.62"	1000 mm 39.37"
	SUPER	450 mm 17.72"	750 mm 29.53"
	TURBO	300 mm 11.81"	500 mm 19.69"
	FINE	150 mm 5.91"	250 mm 9.84"
	HSP	100 mm 3.94"	200 mm 7.87"
Ambient temperature	-10 to +55°C (14 to 131°F) (No freezing)		
Relative humidity	35 to 85% RH (No condensation)		
Material	Case	Glass reinforced plastic	
	Lens cover	Norbornene plastic	Acrylic ¹
Weight	Approx. 65 g		
Dimensions	[P.21]	[P.20]	[P.21]

*1 The LV-NH32 and the LV-NH37 receivers are polyarylate.

LV-Sxx (Retro-reflective)

Type	Small spot	Parallel light area	Long-distance transparent object	
Model	LV-S61	LV-S62	LV-S63	
FDA (CDRH) Part 1040.10	Class 1 Laser Product			
IEC 60825-1	Class 1 Laser Product			
Light source	Visible red semiconductor laser ^{*1}			
Detecting distance*	MEGA	2.5 m 8.2'	12 m (6 m) 39.4' (19.7')	35 m 114.8'
	ULTRA	2 m 6.6'	10 m (5 m) 32.8' (16.4')	30 m 98.4'
	SUPER	1.5 m 4.9'	8 m (3.5 m) 26.2' (11.5')	25 m 82'
	TURBO	1 m 3.3'	5 m (2 m) 16.4' (6.6')	15 m 49.2'
	FINE	0.75 m 2.5'	2.5 m (0.7 m) 8.2' (2.3')	8 m 26.2'
	HSP	0.5 m 1.6'	-	-
Ambient temperature	-10 to +50°C (14 to 122°F) (No freezing)			
Material	Case	Glass reinforced plastic		
	Lens cover	Acrylic		
	Reflective mirror	Polycarbonate, acrylic		
Weight	Approx. 70 g	Approx. 65 g	Approx. 110 g	
Dimensions	[P.18]	[P.18]	[P.19]	

* Numbers enclosed in parentheses are the detecting distance for small beam spot.

*1 Wavelength: LV-S61: 655 nm LV-S62/S63: 660 nm

LV-F1

Type	Side-view attachment for thrubeam		
Model	LV-F1		
Applicable head	LV-S71 LV-S72		
Detecting distance	MEGA	250 mm 9.84"	400 mm 15.75"
	ULTRA		
	SUPER		
	TURBO		
	FINE		
	HSP		
Ambient temperature	-10 to +50°C (14 to 122°F) (No freezing)		
Material	Metal part: SUS304 Mirror part: Glass		
Vibration resistance	10 to 55 Hz, double amplitude: 1.5 mm 0.06"		
Weight	Approx. 22 g		
Dimensions	[P.20]		

LV-NHxx (Spot Retro-Reflective)

Type	Small spot	
Model	LV-NH62	
FDA (CDRH) Part 1040.10	Class 1 Laser Product	
IEC 60825-1	Class 1 Laser Product	
Light source	Visible red semiconductor laser, Wavelength: 660 nm	
Detecting distance	MEGA	8 m 26.2'
	ULTRA	7 m 23'
	SUPER	6 m 19.7'
	TURBO	5 m 16.4'
	FINE	3.5 m 11.5'
	HSP	2 m 6.6'
Ambient temperature	-10 to +55°C (14 to 131°F) (No freezing)	
Material	Case	Glass reinforced plastic
	Lens cover	Norbornene plastic
	Reflective mirror	Polycarbonate, acrylic
Weight	Approx. 65 g	
Dimensions	[P.21]	

LV-NHxx (Area Thrubeam)

Type	High power	High performance
Model	LV-NH110	LV-NH100 LV-NH300
Detecting area	10 mm 0.39"	30 mm 1.18"
FDA (CDRH) Part 1040.10	Class 1 Laser Product	
IEC 60825-1	Class 1 Laser Product	
Light source	Visible red semiconductor laser, Wavelength: 660 nm	
Detecting distance	2000 mm 78.74"	
Ambient temperature	-10 to +55°C (14 to 131°F) (No freezing)	
Relative humidity	35 to 85% RH (No condensation)	
Material	Case	Glass reinforced plastic
	Lens cover	Transmitter: Glass, Receiver: Polyarylate
Weight	Approx. 75 g	Approx. 95 g
Dimensions	[P.22]	[P.22] [P.22]

Example of "width x thickness" of area in LV-L01 detecting distance (Unit: mm inch)

Distance	LV-NH42	LV-NH42 + black slit	LV-NH42 + gray slit	LV-L01	L01 + slit 1	L01 + slit 2	L01 + slit 3	L01 + slit 4
100	26×0.6	13×0.6	5×0.6	27×4	20×4	17×4	13×4	10×4
3.94"	1.02×0.02	0.51×0.02	0.2×0.02	1.06×0.16	0.79×0.16	0.67×0.16	0.51×0.16	0.39×0.16
200	48×0.4	25×0.4	9×0.4	49×7	38×7	32×7	25×7	19×7
7.87"	1.89×0.02	0.98×0.02	0.35×0.02	1.93×0.28	1.5×0.28	1.26×0.28	0.98×0.28	0.74×0.28
300	70×0.8	36×0.8	13×0.8	72×10	56×10	47×10	36×10	27×10
11.81"	2.76×0.03	1.42×0.03	0.51×0.03	2.83×0.39	2.2×0.39	1.85×0.39	1.42×0.39	1.06×0.39
400	92×1.34	48×1.34	17×1.34	94×13	73×13	61×13	48×13	36×13
15.75"	3.62×0.05	1.89×0.05	0.67×0.05	3.7×0.51	2.87×0.51	2.4×0.51	1.89×0.51	1.42×0.51

Amplifier

Cable type

Type	Appearance	Model		Control outputs	External input	Monitor output	Dimensions	
		NPN output	PNP output					
Standard	Main unit		LV-N11N NEW	LV-N11P NEW	2	1	0	[P.23]
	Expansion unit		LV-N12N NEW	LV-N12P NEW				
Monitor output	Main unit		LV-N11MN NEW	-	1	1	1	

M8 connector type

Type	Appearance	Model		Control outputs	External input	Monitor output	Dimensions	
		NPN output	PNP output					
Standard	Main unit		LV-N11CN NEW	LV-N11CP NEW	1	1	0	[P.23]
	Expansion unit		LV-N12CN NEW	LV-N12CP NEW				

Zero line type

Type	Appearance	Model	Control outputs	External input	Monitor output	Dimensions
Standard		LV-N10 NEW	None*1	0	0	[P.23]

*1 Counted as one output when added to an NU Series communication unit.

Specifications

Type	2 output		1 output		Zero line	Monitor output	
Cable/connector	Cable		M8 connector		-	Cable	
Main/Expansion unit	Main unit	Expansion unit	Main unit	Expansion unit	Expansion unit	Main unit	
Model	NPN LV-N11N PNP LV-N11P	LV-N12N LV-N12P	LV-N11CN LV-N11CP	LV-N12CN LV-N12CP	LV-N10	LV-N11MN -	
I/O	Control outputs: 2 output External input: 1 input Monitor output: -		Control outputs: 1 output External input: 1 input Monitor output: -		None	1 output 1 input 1 output	
Response time	80 μs (HIGH SPEED)/250 μs (FINE)/500 μs (TURBO)/1 ms (SUPER)/4 ms (ULTRA)/16 ms (MEGA) * 80 μs cannot be selected when the LV-S31/S62/S63 is connected						
Output selection	LIGHT-ON/DARK-ON (switch-selectable)						
Timer function	Timer OFF/OFF-delay timer/ON-delay timer/One-shot timer, Timer duration selectable: 1 ms to 9,999 ms, Maximum error against the setting value: ±10% max.						
Control outputs	NPN output: NPN open collector 30 V, Residual voltage 1 V or less (Output current: 10 mA or less) / 2 V or less (Output current: 10 to 100 mA)(Stand-alone) 1 output max: 100 mA or less; 2 output total: 100 mA or less (Multiple connections) 1 output max: 20 mA or less PNP output: PNP open collector 30 V, Residual voltage 1.2 V or less (Output current: 10 mA or less) / 2.2 V or less (Output current: 10 to 100 mA)(Stand-alone) 1 output max: 100 mA or less; 2 output total: 100 mA or less (Multiple connections) 1 output max: 20 mA or less						
Monitor output (LV-N11MN only)	1 to 5 V voltage output; load resistance 10 kΩ or more; repeat precision ±0.5% of F.S.; response time: 1 ms (HIGH SPEED, FINE, TURBO), 1.2 ms (SUPER), 1.8 ms (ULTRA), 4.2 ms (MEGA) Input time 2 ms (ON)/20 ms (OFF) or more*1						
External input	Up to 17 units can be connected in total (two-output type is treated as two units)						
Multiple connections to expansion units	Up to 17 units can be connected in total (two-output type is treated as two units)						
Protection circuit	Reverse polarity protection, Over-current protection, Surge absorber						
Number of interference prevention units*4	Connected to other than LV-S31: 0 for HIGH SPEED; 2 for FINE/TURBO/SUPER; 4 for ULTRA/MEGA, Connected to LV-S31: 2 for FINE; 4 for TURBO/SUPER/ULTRA/MEGA						
Rating	Power consumption*5	24 VDC (operating voltage 10-30 VDC (with ripple)), ripple (P-P) 10% or less, Class 2 or LPS*7				-	-
		Normal: 830 mW or less (at 30 V, 30 mA at 24 V, 56 mA or less at 12 V)*2 Eco on mode: 710 mW or less (at 30 V, 26 mA at 24 V, 48 mA or less at 12 V)*2 Eco Full mode: 550 mW or less (at 30 V, 21 mA at 24 V, 40 mA or less at 12 V)					
Environmental resistance	Ambient temperature	-20 to +55°C (-4 to +131°F) (No freezing)*3				-	-
	Relative humidity	35 to 85% RH (No condensation)					
	Vibration resistance	10 to 55 Hz, double amplitude: 1.5 mm 0.06", 2 hours each in the X, Y and Z axis					
	Shock resistance	500 m/s ² 3 times for each of X, Y and Z axis					
Material	Case	Main unit and cover material: Polycarbonate				-	-
	Cable	PVC					
Case size	H 32.6 mm 1.28" × W 9.8 mm 0.39" × L 78.7 mm 3.1"						
Weight	Approx. 75 g	Approx. 65 g	Approx. 20 g	Approx. 20 g	Approx. 20 g	Approx. 75 g	

*1 Input time is 25 ms (ON)/25 ms (OFF) when external calibration time is selected. *2 Increases 30 mW (1 mA) for HIGH SPEED mode.
 *3 If more than one unit is used together, the ambient temperature varies with the conditions below. Mount the units on the DIN rail with mounting brackets and check that the output current is 20 mA or less for a unit.
 One or two more units connected: -20°C to +55°C (-4°F to + 131°F); 3 to 10 more units connected: -20°C to +50°C (-4°F to + 122°F); 11 to 16 more units connected: -20°C to +45°C (-4°F to + 113°F). When using 2-outputs, one unit is counted as two units.
 *4 These numbers double when "DOUBLE" is selected.
 *5 To connect more than 9 units, the power voltage must be 20 V or more.
 *6 It increases by 15% when connected to the LV-NH100/NH110/NH300. It does not include the power consumption of the load.
 *7 Power consumption when expansion units are connected is the total power consumption of each amplifier unit. Example: When one main unit (LV-N11N) is connected to 2 expansion units (LV-N12N) and they are used with LV-NH100 heads in HIGH SPEED mode.
 (1.15 × 860 mW × 1) + (1.15 × 860 mW × 2) = 2967 mW max.
 *7 Use with the over current protection device which is rated 30 V or more and not more than 1 A.

I/O Circuit Diagram

Cable type

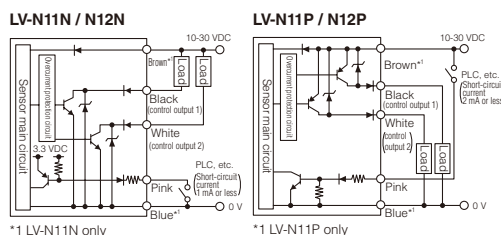

M8 connector type

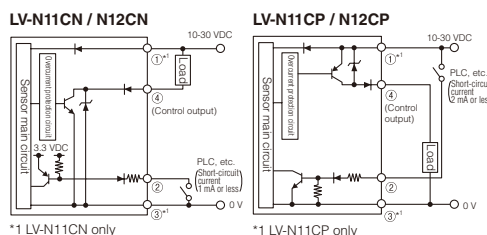

Monitor output type

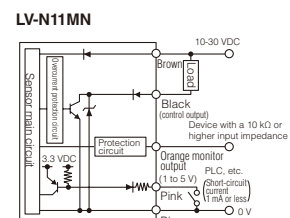

Sensor Head Dimensions

LV-S71

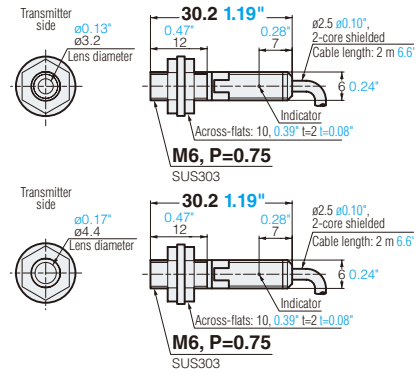

LV-S72

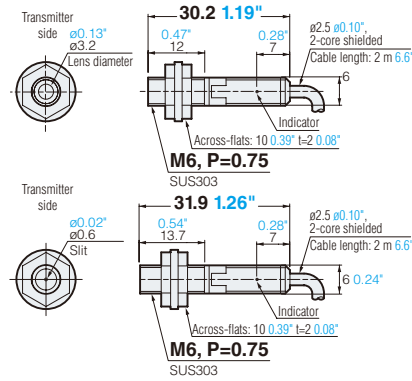

LV-S71 / S72 Mounting bracket (accessory)

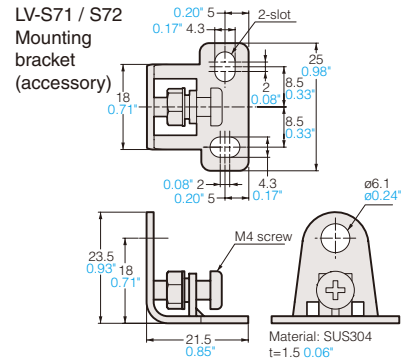

LV-F1

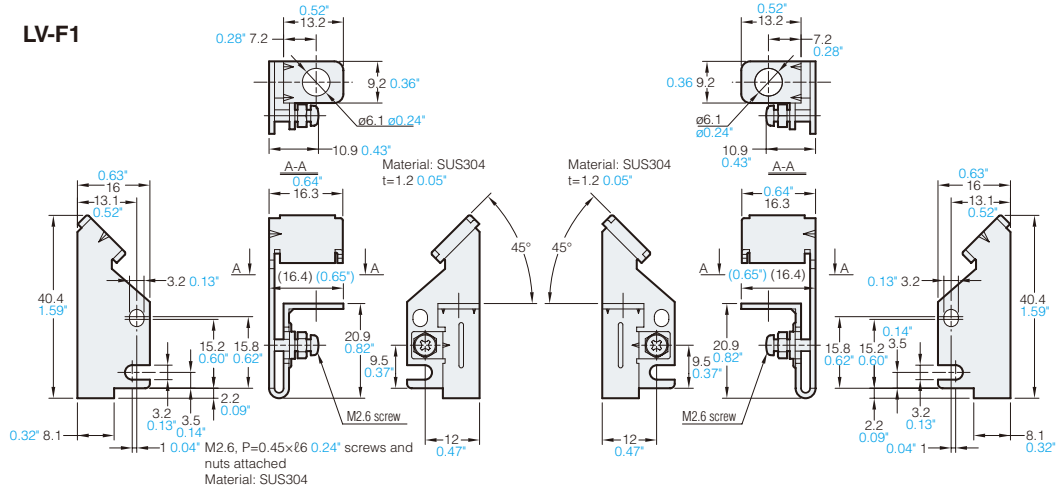

OP-66869

Small mounting bracket for thrubeam (sold separately)

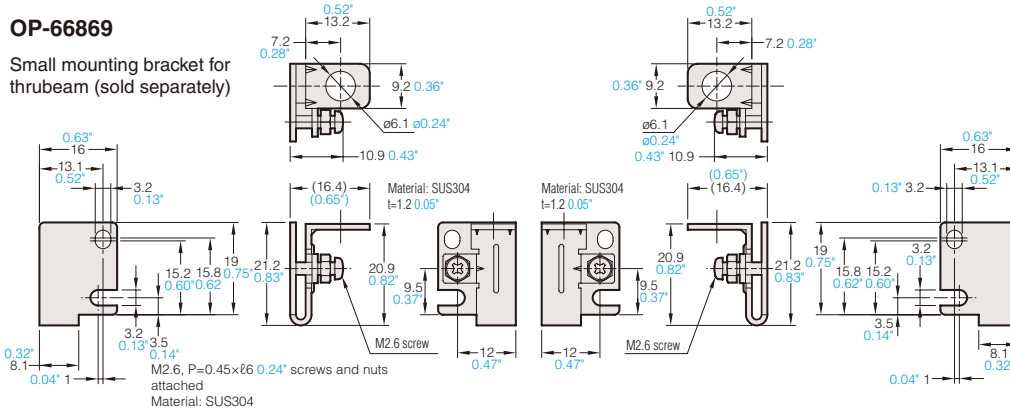

LV-NH Series, Reflective/Retro-Reflective

LV-NH32

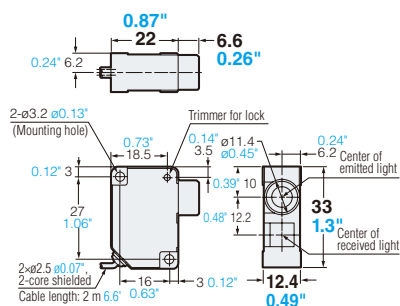

Mounting bracket for the LV-NH32 (accessory)

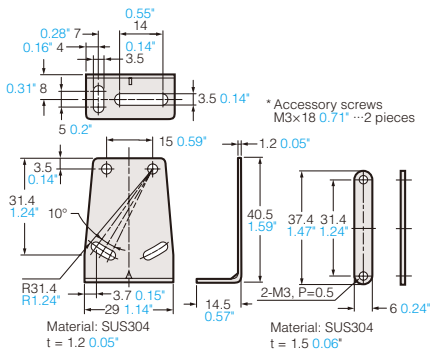

LV-NH32 (with bracket)

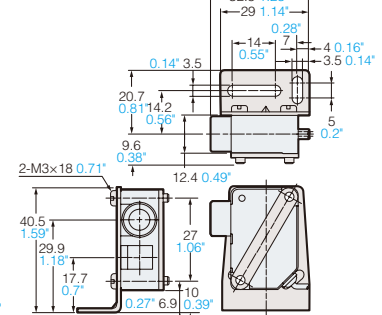

Unit : mm inch

LV-NH35/NH62

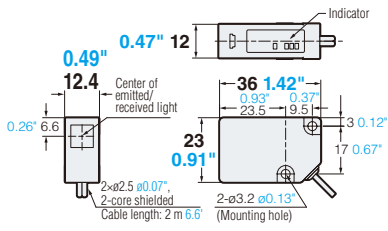

Mounting bracket (accessory)

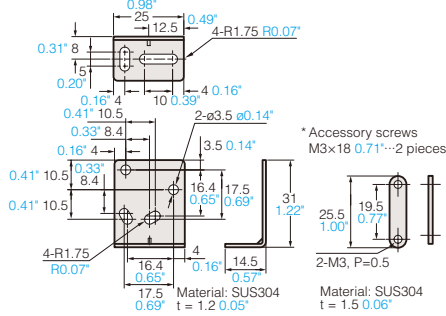

LV-NH35 / NH62 (with bracket)

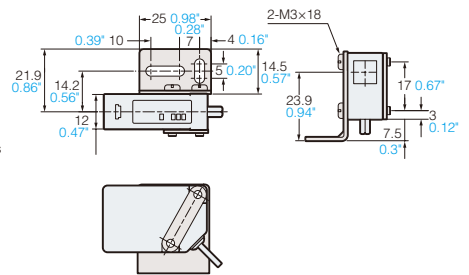

Reflector R-6 (Included with LV-NH62)

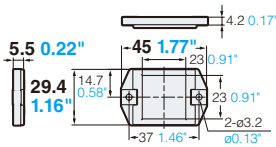

Reflector R-7 (Included with LV-NH62)

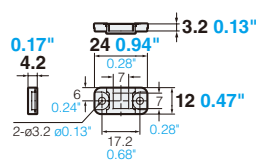

Reflective tape OP-42197 OP-87123

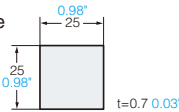

LV-NH37

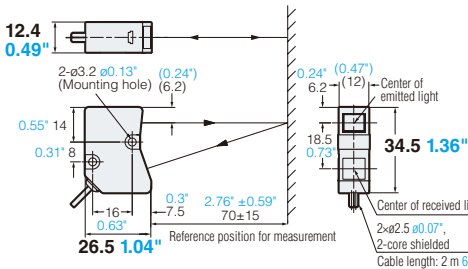

Mounting bracket for the LV-NH37 (accessory)

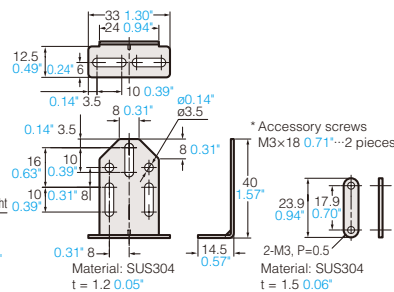

LV-NH37 (with bracket)

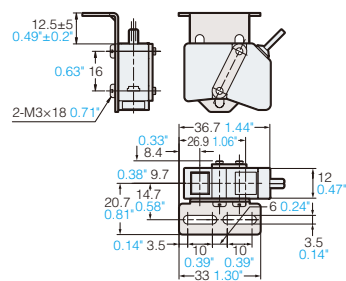

LV-NH42

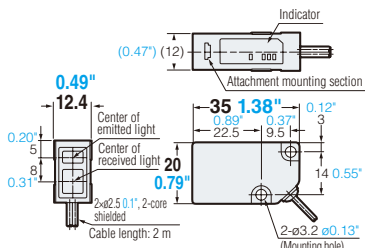

Mounting bracket for the LV-NH42 (accessory)

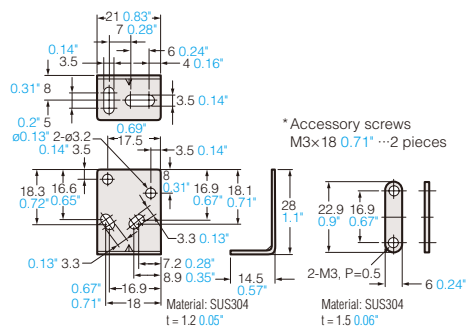

LV-NH42 (with bracket)

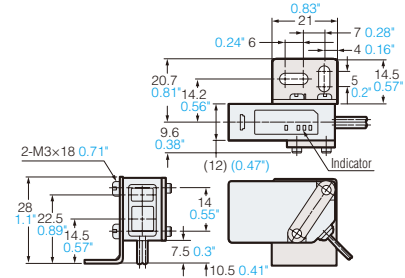

When a slit included with LV-NH42 is attached

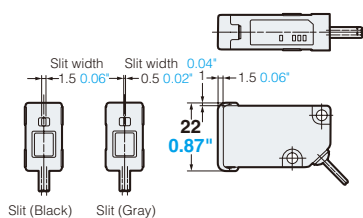

When LV-L01 is attached (LV-NH42)

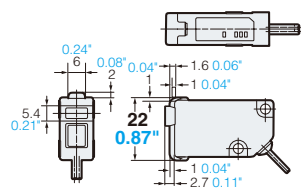

Slit seal (Included with the LV-L01)

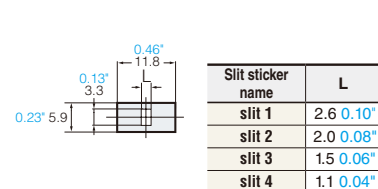

Amplifier Dimensions

CAD Data Download: www.keyence.com/CADG

LV-N11N / N11P / N11MN Cable type, Main unit

ø3.9 ø0.15", 5-core x Brown/Blue: 0.34 mm², Black/White/Pink: 0.18 mm²
Cable length: 2 m 6.56"

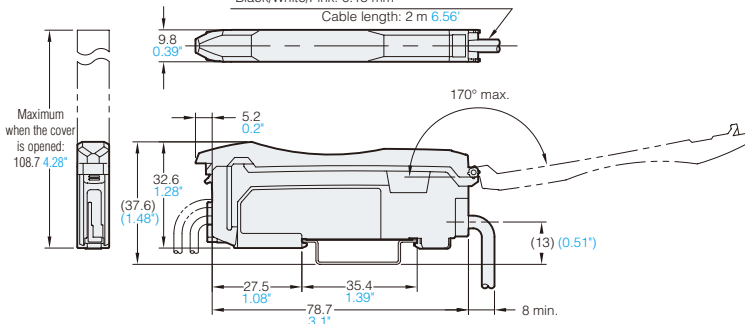

* LV-N11MN: ø3.9 ø0.15", 5-core x Brown/Blue: 0.34 mm², Black/Orange/Pink: 0.18 mm²

LV-N12N / N12P Cable type, Expansion unit

ø3.9 ø0.15", 3-core x Black/White/Pink: 0.18 mm²
Cable length: 2 m 6.56"

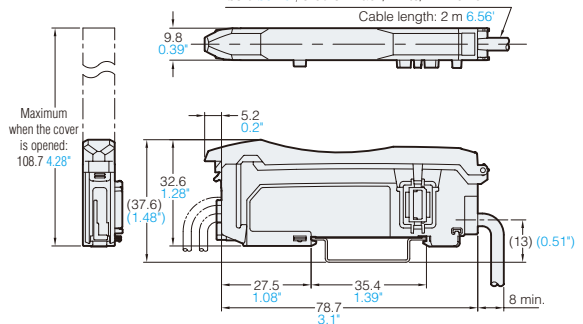

LV-N11CN / N11CP M8 connector type, Main unit

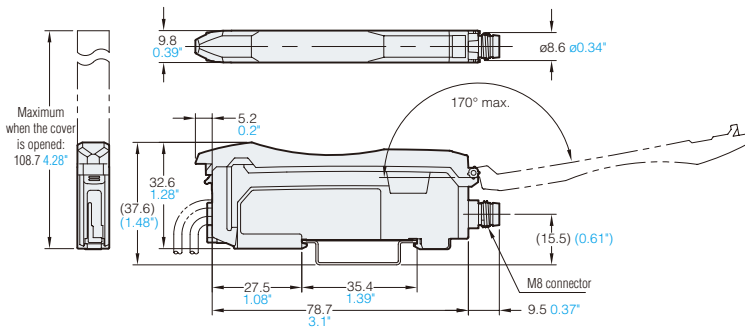

LV-N12CN / N12CP M8 connector type, Expansion unit

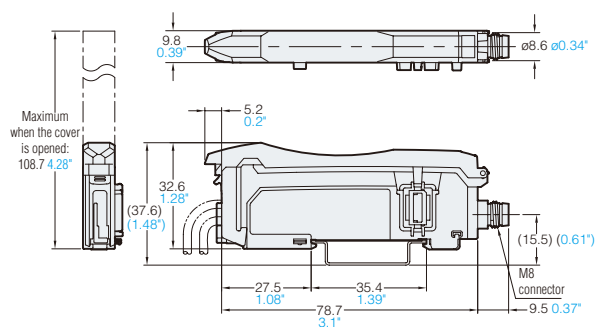

M8 connector cable (OP-73864 / 73865 sold separately)

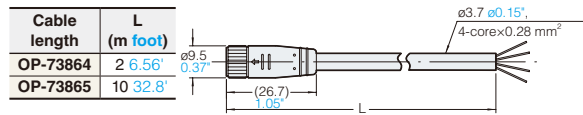

M8 connector junction cable (OP-85498 sold separately)

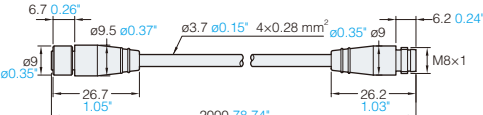

LV-N10 Zero line type, Expansion unit

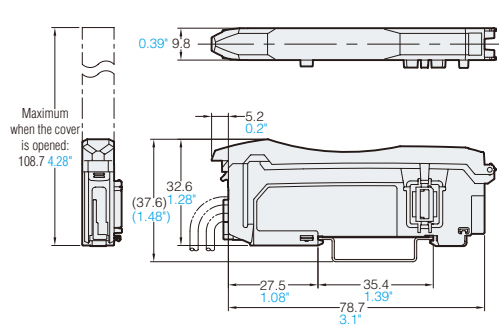

OP-87199 Conversion adaptor



When the end unit is attached (OP-26751 sold separately)

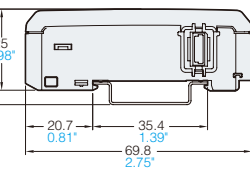
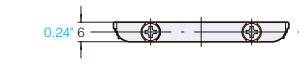

DIN-rail mounting

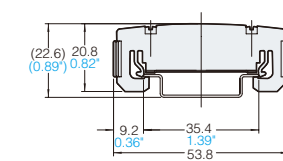

Material: Polycarbonate

Common for all types

When several units are connected:

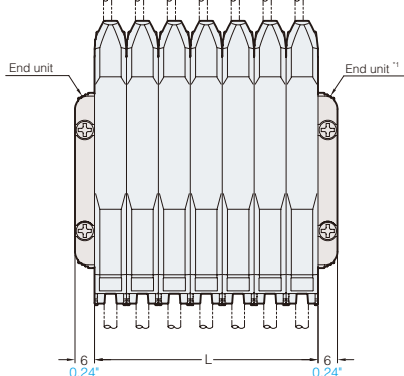

No. of units	L (mm inch)
1	9.8 0.39"
2	19.6 0.77"
3	29.4 1.16"
4	39.2 1.54"
5	49.0 1.93"
6	58.8 2.31"
7	68.6 2.7"
8	78.4 3.09"
9	88.2 3.47"
10	98.0 3.86"
11	107.8 4.24"
12	117.6 4.63"
13	127.4 5.02"
14	137.2 5.4"
15	147.0 5.79"
16	156.8 6.17"
17	166.6 6.56"

*1 End units must be used when several units are connected. (OP-26751)

When the mounting bracket is attached (OP-73880 sold separately)

Cable type

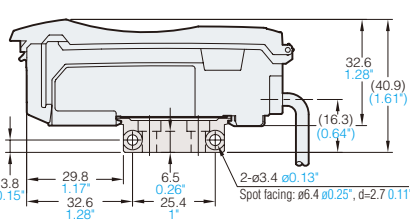

Reverse side of mounting bracket

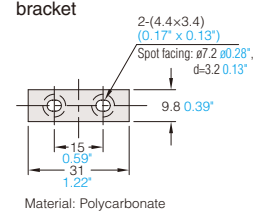

Material: Polycarbonate

M8 connector type

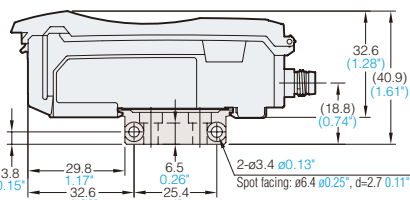

More than 100 fiber unit variations to support a wide range of applications



neo PRESET

A high-function amplifier and vast array of sensor head options provide easy solutions for the most challenging detection conditions.

1 Extensive variety of fiberoptic units

The fiberoptic series has the largest selection of sensor head options which provide a vast range of installation methods and detection solutions.

2 High power enables use in a wide range of applications

With the touch of a button, light intensity can easily be switched to 64 times the normal intensity. This high power is often needed for long-distance detection or in adverse environmental conditions where strong light intensity is required.

3 Automatic maintenance

Even if debris build-up causes the light intensity to drop, the sensor automatically detects the drop in intensity, and re-calibrates to the original display state.

FS-NEO FUNCTION

NEO Preset NEW

Simply press the PRESET button to change the light intensity display to 100 or 0 to complete the sensitivity settings.

NEO MEGA switch

Simply slide the MEGA switch to immediately obtain 64 times the normal light intensity.

Built-in application modes

Advanced mode settings are pre-programmed into the amplifier. Simply choose a mode according to the application and the optimal settings are automatically selected.

DATUM function

Open field network compatibility

Reduced wiring

Interference prevention function

Pause function

Sleep function

Saturation Avoidance function

Avoid light interference up to 30,000 lux

Strong resistance to the effects of sunlight and fluorescent lighting enables stable detection.

Analog output type (FS-N11MN)

The wide variety of fiber head options provide solutions to a vast range of mounting needs and application conditions.

Mounting options

Threaded mounting 	Set screw mounting 	Integrated bracket mounting 	Limited space mounting
------------------------------	-------------------------------	--	-----------------------------------

Detection options

Transparent targets 	Repeated bending 	Small targets 	Variable target position
Oil/Water environments 	High temperature environments 	Vacuum environments 	Chemical environments

NEO MEGA - 64 times the power with one switch

The amplifiers are equipped with 5 light transmission modes for increasing the light intensity when higher power is required. The most powerful of these modes is "MEGA Mode". The power can be increased 64-fold from normal power by simply using 1 switch.

[Normal] FINE Mode		64 times the normal light intensity with one switch!		Ample light intensity can be ensured even when using small diameter fiber optics.
[2x] TURBO Mode				Sufficient reflection can be ensured even with transparent objects
[4x] SUPER Mode				Sufficient variation can be obtained even when distinguishing between 1 or 2 sheets
[16x] ULTRA Mode				Sufficient reflection can be ensured even from black targets
[64x] MEGA Mode				

* There is also a high-speed response HSP mode.

Simply slide the MEGA switch to the right

Automatic maintenance DATUM function

The automatic maintenance function detects light intensity reduction due to dirt or misalignment, and returns the sensor to its original display state. This feature can cancel the effects of the ambient environment, enabling continuous and highly accurate detection.

As build-up occurs, the setting value changes according to light intensity. Datum corrects the setting value based on a running average of this received light intensity value. Since the display values are scaled, the current value is displayed as an even "100.0" rather than an arbitrary value, making target presence evident.

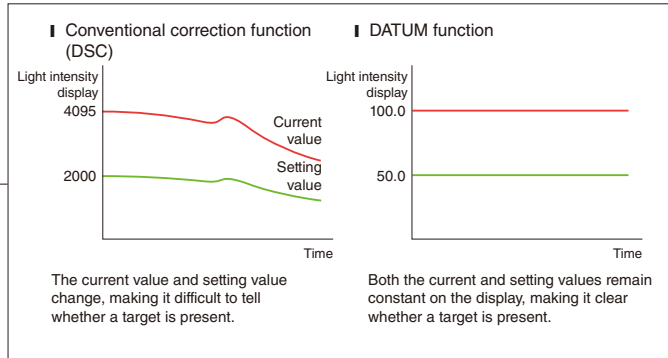

Saturation Avoidance function adjusts the optimum power to prevent excess light intensity

When a small target is being detected by a thru-beam sensor, or when a reflective sensor experiences background reflections, the ambient light may be too strong and might interfere with accurate target detection. In this case, simply press two buttons, and this function will automatically adjust the light intensity to the optimum level.

Excess light intensity causes the display value to go off the scale.

Target present No target

Light transmission level and light intensity gain are automatically calibrated so stable detection can be achieved.

Target present No target

Use the Saturation Avoidance function in the following examples

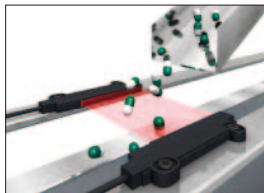

[Area / Thru-beam model]
Target is small / thin
Light travels around the target.

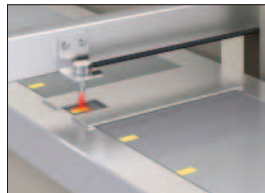

[Reflective model]
Background reflection is strong
The difference in light intensity may be lost.

Simply press MODE and SET at the same time.

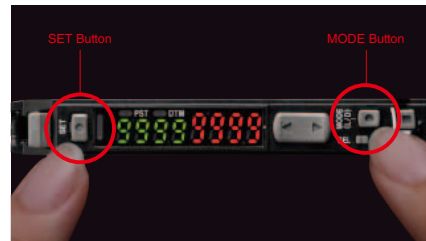

Power-saving Sleep function

This function holds the amplifier in a power save state during external signal input. The normal display is restored after any key is pressed.



Once sleep mode is entered, light transmission is stopped and the display monitor switches off. A single segment on the digital monitor pulses across the display.

KEYENCE Reduced wiring link

Conventional sensors can also be connected for a dramatic reduction in wiring and installation time.

By using the OP-87199 conversion connector **4** on conventional KEYENCE sensors, the NEO Series sensors can easily be connected to significantly reduce wiring and installation time.

<Example connection of NEO Series and conventional sensors>

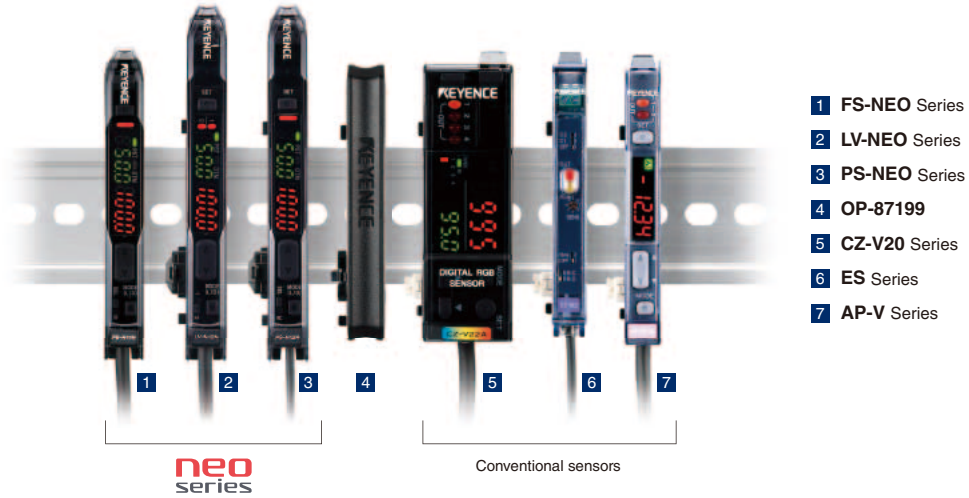

Connection method supporting open field networks

Support for open field networks via the sensor input unit

The NEO Series **2 3 4** is able to support open field networks by using the NU Series **1**. Conventional sensors **7 8 9** are supplied with power simply by connecting expansion units. The sensor output information can be transmitted by connecting e-CON to the NU-EN8N sensor input unit **5**.

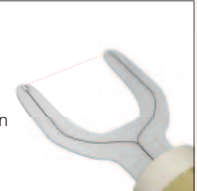

Standard/Simple Mounting	<p>Threaded and Hex-shaped Fibers</p> <p>Threaded for easy mounting onto brackets and machine equipment.</p>  <p>Thrubeam type ▶ P.29 Reflective model ▶ P.34</p>	<p>Cylindrical (Set Screw Installation)</p> <p>Suitable for installation in locations where space is limited. Installed by drilling a hole and using a set screw.</p>  <p>Thrubeam type ▶ P.29 Reflective model ▶ P.35</p>	<p>Integrated bracket</p> <p>The sensor is integrated into an L-shaped bracket, which simplifies installation.</p>  <p>Thrubeam type ▶ P.30 Reflective model ▶ P.35</p>	
	Small Spot/Focused Beam	<p>Small Spot Reflective</p> <p>Great for small object detection. Spot size and focal distance are adjustable, so there is no need to change the distance between the sensor and the target.</p>  <p>Reflective model ▶ P.36</p>	<p>Focused Beam/High power</p> <p>Use of a lens reduces the field of view based on the aperture angle. This narrow beam helps avoid deflection and is suitable for detecting objects at longer distances.</p>  <p>Thrubeam type ▶ P.30 Reflective model ▶ P.37</p>	
Transparent object detection		<p>Retro-reflective</p> <p>Effective for detecting transparent objects. The beam passes through the (transparent) target twice, so light attenuation increases.</p>  <p>Retro-reflective Type ▶ P.40</p>	<p>Definite-reflective</p> <p>Detects within a fixed range. Reduces background effects and features a space-saving, thin profile design.</p>  <p>Reflective model ▶ P.37</p>	
	Small space	<p>Flat Bracket Fibers</p> <p>This thin profile sensor comes with mounting holes for installation where space is limited.</p>  <p>Thrubeam type ▶ P.31 Reflective model ▶ P.37</p>	<p>Sleeve</p> <p>The thin sleeve design eliminates problems caused by limited mounting space and allows the sensor to be placed closer to the target. Lineup includes side-view and bendable sleeve types.</p>  <p>Thrubeam type ▶ P.31 Reflective model ▶ P.38</p>	
Environment-proof		<p>Oil/Chemical Resistant</p> <p>The fluorocarbon resin coating allows these fibers to be used in almost any environment, including oil or chemical-splash conditions.</p>  <p>Thrubeam type ▶ P.32 Reflective model ▶ P.38</p>	<p>High-flex</p> <p>Provides higher flexibility than an electric wire. Resistant to 30 million bends!</p>  <p>Thrubeam type ▶ P.32 Reflective model ▶ P.39</p>	<p>Heat Resistant</p> <p>Ideal for use in high temperature applications. Withstands temperatures up to 350°C 662°F.</p>  <p>Thrubeam type ▶ P.32 Reflective model ▶ P.39</p>
	Dedicated application	<p>Area</p> <p>The wide-area beam is ideal for applications where there is variance in target position and for detecting multiple shapes or moving targets.</p>  <p>Thrubeam type ▶ P.33 Reflective model ▶ P.40</p>	<p>Liquid-level</p> <p>Accurate liquid level detection sensors are available in transparent tube-mount or immersion type models.</p>  <p>Reflective model ▶ P.40</p>	<p>Vacuums</p> <p>Can be used in vacuum and high temperature environment.</p>  <p>Thrubeam type ▶ P.41</p>
Amplifiers ▶ P.42		<p>Cable Type M8 connector Type Zero line Type</p> 		

Thrubeam type Standard/Simple Mounting Type

Threaded and Hex-shaped Fibers

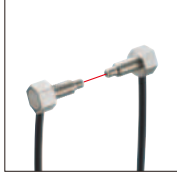

Threaded fibers must be mounted onto brackets before use.

Benefits!

With the hex-shaped fiber, one end is secured with a nut, making installation easier.

Stainless steel braided cable is recommended in areas where the fiber can be damaged due to machine operator activity.

Size/Shape	Fiber unit length (Diameter) Ambient temperature Appearance (mm)	Cable bend radius (mm)	Detecting distance (mm)*1		Optical axis diameter (mm) (Standard target to be detected)	Minimum Detectable object (mm)*2	Model / Weight	Dimensions
			MEGA FINE	Other power modes				
M4	Hex-shaped	R2 R0.08" ToughFlex	MEGA : 3100 122.05" FINE : 640 25.20"	ULTRA : 2100 82.63" SUPER : 1300 51.18" TURBO : 880 34.65" HSP : 320 12.60"	ø1.13 ø0.04"	ø0.005 ø0.0002"	FU-77TZ	[P.48]
							FU-77TG	[P.48]
	Threaded	R0.5 R0.02" ToughFlex	MEGA : 3600 141.73" FINE : 880 34.65"	ULTRA : 3000 118.11" SUPER : 1800 70.87" TURBO : 1300 51.18" HSP : 430 16.93"			FU-77V	[P.47]
							R2 R0.08" ToughFlex	FU-77
		R10 R0.39" Stainless Steel	MEGA : 1800 70.87" FINE : 880 34.65"	ULTRA : 1800 70.87" SUPER : 1800 70.87" TURBO : 1300 51.18" HSP : 430 16.93"			FU-77G	[P.47]
		R25 R0.98" Lens attachment [P.33]	MEGA : 3600 141.73" FINE : 1100 43.31"	ULTRA : 3200 125.98" SUPER : 2200 86.61" TURBO : 1500 59.06" HSP : 540 21.26"			FU-7F	[P.47]
M6	Threaded	R4 R0.16" Lens attachment [P.33]	MEGA : 2200 86.61" FINE : 440 17.32"	ULTRA : 1400 55.12" SUPER : 860 33.86" TURBO : 600 23.62" HSP : 220 8.66"	ø1 ø0.04"	ø0.005 ø0.0002"	FU-78	[P.48]
		R25 R0.98" Lens attachment [P.33]	MEGA : 3600 141.73" FINE : 1100 43.31"	ULTRA : 3600 141.73" SUPER : 2300 90.55" TURBO : 1600 62.99" HSP : 590 23.23"			FU-71Z	[P.47]
	R2 R0.08" ToughFlex	MEGA : 3600 141.73" FINE : 1300 51.18"	ULTRA : 3600 141.73" SUPER : 2600 102.36" TURBO : 1800 70.87" HSP : 650 25.59"	ø1.5 ø0.06"	FU-71		[P.47]	
	R25 R0.98" ToughFlex	MEGA : 3600 141.73" FINE : 1100 43.31"	ULTRA : 3600 141.73" SUPER : 2300 90.55" TURBO : 1600 62.99" HSP : 590 23.23"		FU-71Z		[P.47]	

*1 When using the FS-N Series, "3600 mm 141.73" is assumed as maximum because the fiber cable has a length of 2 m 6.6'.
*2 The smallest detectable object was determined at the optimal detecting distance and sensitivity setting.

Cylindrical (Set Screw Installation)

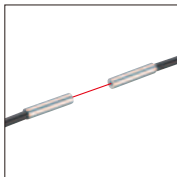

Installed by drilling a hole and using a set screw. Suitable for installation in locations where space is limited.

Size	Fiber unit length (Diameter) Ambient temperature Appearance (mm)	Cable bend radius (mm)	Detecting distance (mm)*1		Optical axis diameter (mm) (Standard target to be detected)	Minimum Detectable object (mm)*2	Model / Weight	Dimensions
			MEGA FINE	Other power modes				
ø1.0 ø0.04"	1 m 3.3' Free-cut (ø1.0) (ø0.04) -40 to +50°C (-40 to +122°F) ø1 ø0.04" 6 0.24"	R2 R0.08" ToughFlex High-flex	MEGA : 590 23.23" FINE : 140 5.51"	ULTRA : 430 16.93" SUPER : 300 11.81" TURBO : 180 7.09" HSP : 55 2.17"	ø0.5 ø0.02"	ø0.005 ø0.0002"	FU-58U	[P.46]
		R10 R0.39"	MEGA : 380 14.96" FINE : 85 3.35"	ULTRA : 270 10.63" SUPER : 180 7.09" TURBO : 120 4.72" HSP : 40 1.57"			FU-58	[P.46]
ø1.5 ø0.06"	1 m 3.3' Free-cut (ø1.0) (ø0.04) -40 to +50°C (-40 to +122°F) ø1.5 ø0.06" 10 0.39"	R2 R0.08" ToughFlex High-flex	MEGA : 590 23.23" FINE : 140 5.51"	ULTRA : 430 16.93" SUPER : 300 11.81" TURBO : 180 7.09" HSP : 55 2.17"	ø0.5 ø0.02"	ø0.005 ø0.0002"	FU-59U	[P.47]
		R4 R0.16" High-flex	MEGA : 1200 47.24" FINE : 230 9.06"	ULTRA : 810 31.89" SUPER : 590 23.23" TURBO : 410 16.14" HSP : 130 5.12"			FU-59	[P.46]
ø2.5 ø0.10"	50 cm 19.69' cut not allowed -40 to +70°C (-40 to +158°F) ø2.5 ø0.10" 10 0.39"	R10 R0.39"	MEGA : 45 1.77" FINE : 13 0.51"	ULTRA : 32 1.26" SUPER : 23 0.91" TURBO : 18 0.71" HSP : -	ø0.125 ø0.005"	ø0.005 ø0.0002"	FU-55	[P.46]
							50 cm 19.69' cut not allowed -40 to +70°C (-40 to +158°F) ø0.3 ø0.01" 10 0.39"	FU-56
ø3 ø0.12"	2 m 6.6' Free-cut (ø2.2) (ø0.09) -40 to +50°C (-40 to +122°F) ø3 ø0.12" 14 0.55"	R2 R0.08" ToughFlex	MEGA : 3600 141.73" FINE : 880 34.65"	ULTRA : 3000 118.11" SUPER : 1800 70.87" TURBO : 1300 51.18" HSP : 430 16.93"	ø1.13 ø0.04"	ø0.005 ø0.0002"	FU-5FZ	[P.46]
		R25 R0.98"	MEGA : 3600 141.73" FINE : 1100 43.31"	ULTRA : 3200 125.98" SUPER : 2200 86.61" TURBO : 1500 59.06" HSP : 540 21.26"			FU-5F	[P.46]

*1 When using the FS-N Series, "3600 mm 141.73" is assumed as maximum because the fiber cable has a length of 2 m 6.6'.
*2 The smallest detectable object was determined at the optimal detecting distance and sensitivity setting.

Integrated bracket

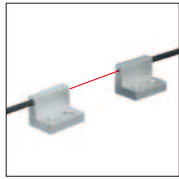

The bracket and sensor are integrated.

Benefits!

Eliminate concerns about bracket design, bracket and sensor assembly, or loose brackets. Integrated designs reduce space requirements.

Beam emitting direction	Optical axis height	Fiber unit length (Diameter) Ambient temperature Appearance (mm)	Cable bend radius (mm)	Detecting distance (mm) ^{*1}		Optical axis diameter (mm) (Standard target to be detected)	Minimum Detectable object (mm) ^{*2}	Model / Weight	Dimensions	
				MEGA FINE	Other power modes					
Top	10 mm 0.39"	2 m 6.6' Free-cut (ø2.2) (ø0.09) -40 to +50°C (-40 to +122°F) 0.48" 12.2" 17" 0.67" 2-ø3.4 ø0.13"	R2 R0.08" ToughFlex	MEGA : 2200 86.61" FINE : 450 17.72"	ULTRA : 1700 66.93" SUPER : 1000 39.37" TURBO : 780 29.92" HSP : 290 11.42"	ø1.13 ø0.04"	ø0.005 ø0.0002"	FU-L51Z Approx. 30 g	[P.50]	
	15 mm 0.59"	2 m 6.6' Free-cut (ø2.2) (ø0.09) -40 to +50°C (-40 to +122°F) 0.67" 17" 12.2" 17" 0.67" 2-ø3.4 ø0.13"								FU-L52Z Approx. 30 g
	20 mm 0.79"	2 m 6.6' Free-cut (ø2.2) (ø0.09) -40 to +50°C (-40 to +122°F) 0.67" 17" 12.2" 17" 0.67" 2-ø3.4 ø0.13"								
Top (Built-in lens)	10 mm 0.39"	2 m 6.6' Free-cut (ø2.2) (ø0.09) -40 to +50°C (-40 to +122°F) 0.51" 13" 14" 20" 0.79" 2-ø3.4 ø0.13"	R2 R0.08" ToughFlex	MEGA : 3600 141.73" FINE : 3100 122.05"	ULTRA : 3600 141.73" SUPER : 3600 141.73" TURBO : 3600 141.73" HSP : 2100 82.68"	ø3.5 ø0.14"	ø0.2 ø0.008"	FU-L50Z Approx. 30 g	[P.50]	
Side	10 mm 0.39"	2 m 6.6' Free-cut (ø2.2) (ø0.09) -40 to +50°C (-40 to +122°F) 0.67" 17" 12.8 0.50" 12.8 0.50" 2-ø3.4 ø0.13"		R2 R0.08" ToughFlex	MEGA : 1900 74.80" FINE : 410 16.14"	ULTRA : 1500 59.06" SUPER : 900 35.43" TURBO : 700 27.56" HSP : 270 10.63"	ø1.13 ø0.04"	ø0.005 ø0.0002"	FU-L54Z Approx. 30 g	[P.50]

*1 When using the FS-N Series, "3600 mm 141.73" is assumed as maximum because the fiber cable has a length of 2 m 6.6'.

*2 The smallest detectable object was determined at the optimal detecting distance and sensitivity setting.

Thrubeam type Small Spot/Focused Beam Type

Focused Beam / High power

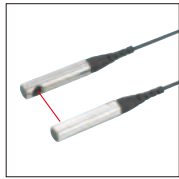

Use of a lens narrows beam width and helps avoid deflection.

Beam emitting direction	Aperture angle	Fiber unit length (Diameter) Ambient temperature Appearance (mm)	Cable bend radius (mm)	Detecting distance (mm) ^{*1}		Optical axis diameter (mm) (Standard target to be detected)	Minimum Detectable object (mm) ^{*2}	Model / Weight	Dimensions
				MEGA FINE	Other power modes				
Side	Approx. 6°	2 m 6.6' Free-cut (ø1.0) (ø0.04) FU-16Z: -40 to +50°C (-40 to +122°F) FU-16/18: -40 to +70°C (-40 to +158°F) ø0.16" ø4 13 0.51" 17 0.67"	R2 R0.08" ToughFlex	MEGA : 3600 141.73" FINE : 1260 49.61"	ULTRA : 3600 141.73" SUPER : 2600 102.36" TURBO : 1800 70.87" HSP : 760 29.92"	ø2.5 ø0.10"	ø0.1 ø0.004"	FU-16Z Approx. 8 g	[P.44]
		MEGA : 3600 141.73" FINE : 1900 74.80"		ULTRA : 3600 141.73" SUPER : 3600 141.73" TURBO : 2700 106.30" HSP : 1000 39.37"	FU-16 Approx. 8 g			[P.44]	
	Approx. 2°	2 m 6.6' Free-cut (ø1.0) (ø0.04) -40 to +70°C (-40 to +158°F) 1.5" 0.06" 2" 0.08" 20 0.79"	R10 R0.39"	MEGA : 3600 141.73" FINE : 1600 62.99"	ULTRA : 3600 141.73" SUPER : 3000 118.11" TURBO : 2100 82.68" HSP : 960 37.80"	FU-18 Approx. 8 g	[P.44]		
Approx. 3°	2 m 6.6' Free-cut (ø1.0) (ø0.04) -40 to +70°C (-40 to +158°F) 1.5" 0.06" 2" 0.08" 20 0.79"	R2 R0.08" ToughFlex	MEGA : 1300 51.18" FINE : 330 12.99"	ULTRA : 900 35.43" SUPER : 680 26.77" TURBO : 530 20.87" HSP : 210 8.27"	FU-18M Approx. 6 g	[P.44]			
Top	Approx. 6°	2 m 6.6' Free-cut (ø1.0) (ø0.04) -40 to +50°C (-40 to +122°F) 0.16" 4" 3.6 0.14" 12 0.47"	R2 R0.08" ToughFlex	MEGA : 3600 141.73" FINE : 3600 141.73"	ULTRA : 3600 141.73" SUPER : 3600 141.73" TURBO : 3600 141.73" HSP : 2400 94.49"	ø2.8 ø0.11"	ø0.1 ø0.004"	FU-50 Approx. 8 g	[P.46]

*1 When using the FS-N Series, "3600 mm 141.73" is assumed as maximum because the fiber cable has a length of 2 m 6.6'.

*2 The smallest detectable object was determined at the optimal detecting distance and sensitivity setting.

Thrubeam type Space-Saving Type

Flat Bracket Fibers

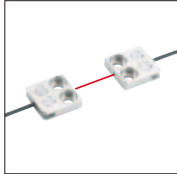

Thin bracket-shaped design for mounting in limited spaces.

Benefits!

Metal housing eliminates concern about damaged sensors. The sensor and case form a flat surface, so there are no openings where dust and other foreign matter can enter.

Beam emitting direction	Fiber unit length (Diameter) Ambient temperature Appearance (mm)	Cable bend radius (mm)	Detecting distance (mm)*1		Optical axis diameter (mm) (Standard target to be detected)	Minimum Detectable object (mm)*2	Model / Weight	Dimensions
			MEGA FINE	Other power modes				
Top	1 m 3.3' Free-cut (ø1.0) (ø0.04') -40 to +50°C (-40 to +122°F) 2-ø2.1 ø0.08" Thickness 3 0.12"	R2 R0.08" ToughFlex	MEGA : 810 31.89" FINE : 170 6.69"	ULTRA : 520 20.47" SUPER : 340 13.39" TURBO : 260 10.24" HSP : 90 3.54"	ø0.5 ø0.02'	ø0.005 ø0.0002'	FU-51TZ Approx. 5 g	[P.46]
	2 m 6.6' Free-cut (ø1.3) (ø0.05') -40 to +50°C (-40 to +122°F) 2-ø3.2 ø0.13" Thickness 3.5 0.14"		MEGA : 2900 114.17" FINE : 610 24.02"	ULTRA : 1900 74.80" SUPER : 1200 47.24" TURBO : 850 33.46" HSP : 260 10.24"	ø1 ø0.04'		FU-52TZ Approx. 15 g	[P.46]
Side	1 m 3.3' Free-cut (ø1.0) (ø0.04') -40 to +50°C (-40 to +122°F) 0.41" 10.5" ø0.08" 2-ø2.1" 0.24" 6.3" Thickness 2.5 0.10"		MEGA : 740 29.13" FINE : 140 5.51"	ULTRA : 480 18.90" SUPER : 280 11.02" TURBO : 200 7.87" HSP : 70 2.76"	ø0.5 ø0.02'	ø0.005 ø0.0002'	FU-57TZ Approx. 5 g	[P.46]
Flat	1 m 3.3' Free-cut (ø1.0) (ø0.04') -40 to +50°C (-40 to +122°F) 0.28" 7" ø0.08" 2-ø2.1" 0.51" 13" Thickness 2 0.08"		MEGA : 500 19.69" FINE : 140 5.51"	ULTRA : 340 13.39" SUPER : 230 9.06" TURBO : 180 7.09" HSP : 80 3.15"	ø1 ø0.04'		FU-53TZ Approx. 10 g	[P.46]
			2 m 6.6' Free-cut (ø2.2) (ø0.09') -40 to +50°C (-40 to +122°F) 7 0.28" 0.59" 15" 2-M3 Thickness 4 0.16"	MEGA : 2900 114.17" FINE : 610 24.02"	ULTRA : 1900 74.80" SUPER : 1200 47.24" TURBO : 850 33.46" HSP : 260 10.24"	ø1 ø0.04'	FU-54TZ Approx. 25 g	[P.46]

*1 When using the FS-N Series.

*2 The smallest detectable object was determined at the optimal detecting distance and sensitivity setting.

FU-51TZ/52TZ can also be used as side-view fibers.

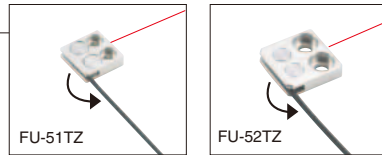

Sleeve

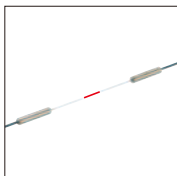

The fiber tip is incorporated into a thin sleeve.

Benefits!

Some long sleeve fibers allow for bending. (See the dimensions diagram for bend radius)

Beam emitting direction	Fiber unit length (Diameter) Ambient temperature Appearance (mm)	Cable bend radius (mm)	Detecting distance (mm)*1		Optical axis diameter (mm) (Standard target to be detected)	Minimum Detectable object (mm)*2	Model / Weight	Dimensions	
			MEGA FINE	Other power modes					
Side	1 m 3.3' Free-cut (ø1.3) (ø0.05') -40 to +70°C (-40 to +158°F) ø0.10" ø2.5" ø0.03" ø0.82" 15 0.59" 15 0.59"	R25 R0.98"	MEGA : 520 20.47" FINE : 100 3.94"	ULTRA : 380 14.96" SUPER : 230 9.06" TURBO : 160 6.30" HSP : 55 2.17"	ø0.6 ø0.02'	ø0.005 ø0.0002'	FU-32 Approx. 5 g	[P.44]	
	2 m 6.6' Free-cut (ø2.2) (ø0.09') -40 to +70°C (-40 to +158°F) 65 2.56" ø3 ø0.12" ø1.2 ø0.05" Min. bend radius of sleeve: R25 R0.98"		MEGA : 1600 62.99" FINE : 330 12.99"	ULTRA : 1100 43.31" SUPER : 660 25.98" TURBO : 470 18.50" HSP : 140 5.51"	ø1 ø0.04'		FU-34 Approx. 17 g	[P.45]	
2 m 6.6' Free-cut (ø2.2) (ø0.09') -40 to +70°C (-40 to +158°F) ø1.65 ø0.06" 67 2.64" Min. bend radius of sleeve: R10 R0.39"	MEGA : 3600 141.73" FINE : 1100 43.31"		ULTRA : 3200 125.98" SUPER : 2200 86.61" TURBO : 1500 59.06" HSP : 540 21.26"	ø0.005 ø0.0002'	FU-73 Approx. 24 g	[P.47]			
Top	1 m 3.3' Free-cut (ø1.0) (ø0.04') -40 to +70°C (-40 to +158°F) ø0.82 ø0.03" M3 15 0.59" 15 0.59"		R10 R0.39"	MEGA : 690 27.17" FINE : 170 6.69"	ULTRA : 500 19.69" SUPER : 340 13.39" TURBO : 240 9.45" HSP : 72 2.83"	ø0.5 ø0.02'	ø0.005 ø0.0002'	FU-75F Approx. 10 g	[P.47]
	1 m 3.3' Free-cut (ø1.0) (ø0.04') -40 to +70°C (-40 to +158°F) ø0.4 ø0.02" 45 1.77" 15 0.59" Min. bend radius of sleeve: R10 R0.39"			MEGA : 370 14.57" FINE : 85 3.35"	ULTRA : 260 10.24" SUPER : 180 7.09" TURBO : 120 4.72" HSP : 40 1.57"	ø0.265 ø0.01'		FU-76F Approx. 10 g	[P.47]
	50 cm 19.69" cut not allowed -40 to +70°C ø0.3" ø0.10" ø2.5" (-40 to +158°F) ø0.01" 10 0.39" 5 0.20" Do not bend sleeve			MEGA : 45 1.77" FINE : 13 0.51"	ULTRA : 32 1.26" SUPER : 23 0.91" TURBO : 18 0.71" HSP : -	ø0.125 ø0.005'		FU-56 Approx. 3 g	[P.46]

*1 When using the FS-N Series. "3600 mm 141.73" is assumed as maximum because the fiber cable has a length of 2 m 6.6'.

*2 The smallest detectable object was determined at the optimal detecting distance and sensitivity setting.

Thrubeam type

Environment-proof

Oil/Chemical Resistant



Sensor is encased in fluorocarbon resin.

High-flex



Suited for use with moving parts.

Heat Resistant



Suited for use at high temperatures of up to 300°C (572°F).

Beam emitting direction	Fiber unit length (Diameter) Ambient temperature Appearance (mm)	Cable bend radius (mm)	Detecting distance (mm) ^{*1}		Optical axis diameter (mm) (Standard target to be detected)	Minimum Detectable object (mm) ^{*2}	Model / Weight	Dimensions
			MEGA FINE	Other power modes				
Top	2 m 6.6' Free-cut (ø2.2) (ø0.09") -40 to +70°C (-40 to +158°F) ø5 ø0.20" 22 0.87"	R40 R1.57"	MEGA : 3600 141.73" FINE : 2800 110.24"	ULTRA : 3600 141.73" SUPER : 3600 141.73" TURBO : 3600 141.73" HSP : 1400 55.12"	ø3.7 ø0.15"	ø0.2 ø0.01"	FU-92 Approx. 71 g	[P.48]
	MEGA : 3600 141.73" FINE : 3600 141.73"		ULTRA : 3600 141.73" SUPER : 3600 141.73" TURBO : 3600 141.73" HSP : 2400 94.49"	ø6 ø0.24"	-	FU-98 NEW Approx. 70 g	[P.49]	
Side	2 m 6.6' Free-cut (ø2.2) (ø0.09") -40 to +70°C (-40 to +158°F) ø5 ø0.20" 23 0.91"	R25 ^{*3} R0.98"	MEGA : 3600 141.73" FINE : 1100 43.31"	ULTRA : 3600 141.73" SUPER : 3000 118.11" TURBO : 2200 86.61" HSP : 510 20.08"	ø2.8 ø0.11"	ø0.1 ø0.004"	FU-96 Approx. 71 g	[P.49]
	2 m 6.6' Free-cut (ø2.2) (ø0.09") 0 to +60°C 0.51" (0 to +140°F) Thickness 7 0.28" 14.3 0.56"		MEGA : 3600 141.73" FINE : 3600 141.73"	ULTRA : 3600 141.73" SUPER : 3600 141.73" TURBO : 3600 141.73" HSP : 2400 94.49"	ø3.7 ø0.15"	ø0.2 ø0.01"	FU-96T NEW Approx. 35 g	[P.49]

*1 When using the FS-N Series, "3600 mm 141.73" is assumed as maximum because the fiber cable has a length of 2 m 6.6'.

*2 The smallest detectable object was determined at the optimal detecting distance and sensitivity setting.

*3 25 mm from the end of screw cap of the housing cannot be bent.

Size	Fiber unit length (Diameter) Ambient temperature Appearance (mm)	Cable bend radius (mm)	Detecting distance (mm) ^{*1}		Optical axis diameter (mm) (Standard target to be detected)	Minimum Detectable object (mm) ^{*2}	Model / Weight	Dimensions
			MEGA FINE	Other power modes				
ø1.0 ø0.04"	1 m 3.3' Free-cut (ø1.0) (ø0.04") -40 to +50°C ø1 ø0.04" (-40 to +122°F) 6 0.24"	R2 R0.08" ToughFlex High-flex	MEGA : 590 23.23" FINE : 140 5.51"	ULTRA : 430 16.93" SUPER : 300 11.81" TURBO : 180 7.09" HSP : 55 2.17"	ø0.5 ø0.02"	ø0.005 ø0.0002"	FU-58U NEW Approx. 4 g	[P.46]
ø1.5 ø0.06"	1 m 3.3' Free-cut (ø1.0) (ø0.04") -40 to +50°C ø1.5 ø0.06" (-40 to +122°F) 10 0.39"						FU-59U NEW Approx. 4 g	[P.47]
M3	1 m 3.3' Free-cut (ø1.0) (ø0.04") -40 to +50°C M3 (-40 to +122°F) 10 0.39"	R4 R0.16" High-flex	MEGA : 1800 70.87" FINE : 850 33.46"	ULTRA : 1800 70.87" SUPER : 1800 70.87" TURBO : 1200 47.24" HSP : 370 14.57"	ø2.3 ø0.09"	ø0.1 ø0.004"	FU-79U NEW Approx. 4 g	[P.48]
M4 Built-in lens	1 m 3.3' Free-cut (ø1.0) (ø0.04") -40 to +50°C M4 (-40 to +122°F) 13 0.51"						FU-70U NEW Approx. 5 g	[P.47]
ø1.5 ø0.06"	1 m 3.3' Free-cut (ø1.0) (ø0.04") -40 to +70°C ø0.06" ø1.5 (-40 to +158°F) 10 0.39"	R4 R0.16" High-flex	MEGA : 1200 47.24" FINE : 230 9.06"	ULTRA : 810 31.89" SUPER : 590 23.23" TURBO : 410 16.14" HSP : 130 5.12"	ø0.7 ø0.03"	ø0.005 ø0.0002"	FU-59 Approx. 3 g	[P.46]
M3	1 m 3.3' Free-cut (ø1.0) (ø0.04") -40 to +70°C M3 (-40 to +158°F) 10 0.39"						FU-79 Approx. 6 g	[P.48]
6x10.5x2.5 0.24" x 0.41" x 0.10"	1 m 3.3' Free-cut (ø1.0) (ø0.04") -40 to +70°C (-40 to +158°F) 0.24" 6" 10.5 0.41"						FU-57TE Approx. 5 g	[P.46]

*1 When using the FS-N Series. *2 The smallest detectable object was determined at the optimal detecting distance and sensitivity setting.

Heat resistant temperature ^{*3}	Fiber unit length (Diameter) Ambient temperature Appearance (mm)	Cable bend radius (mm)	Detecting distance (mm) ^{*1}		Optical axis diameter (mm) (Standard target to be detected)	Minimum Detectable object (mm) ^{*2}	Model / Weight	Dimensions
			MEGA FINE	Other power modes				
100°C ^{*4} (212°F)	2 m 6.6' Free-cut (ø2.2) (ø0.09") -40 to +100°C (-40 to +212°F) 15 0.59"	R5 R0.20" ToughFlex	MEGA : 3600 141.73" FINE : 680 26.77"	ULTRA : 2200 86.61" SUPER : 1600 62.99" TURBO : 900 35.43" HSP : 390 15.35"	ø1 ø0.04"	ø0.005 ø0.0002"	FU-86Z Approx. 25 g	[P.48]
105°C ^{*4} (221°F)	2 m 6.6' Free-cut (ø2.2) (ø0.09") -40 to +105°C (-40 to +221°F) 15 0.59"	R25 R0.98"	MEGA : 3600 141.73" FINE : 1100 43.31"	ULTRA : 3200 125.98" SUPER : 2200 86.61" TURBO : 1500 59.06" HSP : 540 21.26"			FU-86A Approx. 22 g	[P.48]
150°C ^{*5} (302°F)	2 m 6.6' Free-cut (ø2.2) (ø0.09") -40 to +150°C (-40 to +302°F) 17 0.67"	R20 R0.79"	MEGA : 2700 106.30" FINE : 520 20.47"	ULTRA : 1800 70.87" SUPER : 1100 43.31" TURBO : 720 28.35" HSP : 340 13.39"	ø1.5 ø0.06"	ø0.005 ø0.0002"	FU-86H Approx. 35 g	[P.48]
180°C ^{*6} (356°F)	2 m 6.6' Free-cut (ø2.2) (ø0.09") -50 to +180°C (-76 to +356°F) 17 0.67"	R35 R1.38"	MEGA : 2700 106.30" FINE : 570 22.44"	ULTRA : 1900 74.8" SUPER : 1200 47.24" TURBO : 790 31.10" HSP : 380 14.96"			FU-88 Approx. 36 g	[P.48]
200°C (392°F)	2 m 6.6' cut not allowed -40 to +200°C (-40 to +392°F) 15 0.59"	R8 R0.32"	MEGA : 1800 70.87" FINE : 390 15.35"	ULTRA : 1300 51.18" SUPER : 900 35.43" TURBO : 680 26.77" HSP : 250 9.84"	ø1 ø0.04"	ø0.005 ø0.0002"	FU-88K Approx. 30 g	[P.48]
300°C (572°F)	2 m 6.6' cut not allowed -40 to +300°C (-40 to +572°F) 15 0.59"	R25 R0.98"	Lens attachment [P.33]				FU-84C Approx. 66 g	[P.48]

*1 When using the FS-N Series, "3600 mm 141.73" is assumed as maximum because the fiber cable has a length of 2 m 6.6'.

*2 The smallest detectable object was determined at the optimal detecting distance and sensitivity setting.

*3 Use the fiberoptic sensor under dry conditions. Allow some margin for the temperature upper limit when selecting a heat-resistant fiber unit.

*4 The recommended maximum ambient temperature during operation is 90°C (194°F) when constantly using a fiber unit in a high-temperature environment.

*5 The recommended maximum ambient temperature during operation is 130°C (266°F) when constantly using a fiber unit in a high-temperature environment.

*6 The recommended maximum ambient temperature during operation is 150°C (302°F) when constantly using a fiber unit in a high-temperature environment.

Thrubeam type Dedicated application type

Area



Useful in situations where target position varies.

Type	Detecting width	Fiber unit length (Diameter) Ambient temperature Appearance (mm)	Cable bend radius (mm)	Detecting distance (mm)*1		Optical axis diameter (mm)	Model / Weight	Dimensions
				MEGA FINE	Other power modes			
Array	5 mm 0.20"	Thickness 4 0.16" 0.59" 15 2 m 6.6" Free-cut (ø2.2) (ø0.09") -40 to +70°C (-40 to +158°F)	R4*2 R0.16"	MEGA : 2200 86.61" FINE : 440 17.32"	ULTRA : 1400 55.12" SUPER : 840 33.07" TURBO : 540 21.26" HSP : 200 7.87"	Approx. 6×0.3	FU-A05 Approx. 20 g	[P.49]
	10 mm 0.39"	Thickness 4 0.16" 0.79" 20 2 m 6.6" Free-cut (ø2.2) (ø0.09") -40 to +70°C (-40 to +158°F)	R4*2 R0.16"	MEGA : 2200 86.61" FINE : 440 17.32"	ULTRA : 1400 55.12" SUPER : 840 33.07" TURBO : 540 21.26" HSP : 200 7.87"	Approx. 11×0.3	FU-A10 Approx. 20 g	[P.49]
Area	10 mm 0.39"	Thickness 4.2 0.17" 20 0.79" 2 m 6.6" Free-cut (ø2.2) (ø0.09") -40 to +50°C (-40 to +122°F)	R2 R0.08" ToughFlex	MEGA : 3400 133.86" FINE : 1400 55.12"	ULTRA : 2800 110.24" SUPER : 2400 94.49" TURBO : 1700 66.93" HSP : 640 25.20"	10×3	FU-12 Approx. 23 g	[P.44]
	11 mm 0.43"	Thickness 4 0.16" 29.8 1.17" 2 m 6.6" Free-cut (ø2.2) (ø0.09") -40 to +50°C (-40 to +122°F)		MEGA : 3600 141.73" FINE : 2700 106.30"	ULTRA : 3600 141.73" SUPER : 3600 141.73" TURBO : 3600 141.73" HSP : 1300 51.18"	11×2	FU-E11 Approx. 20 g	[P.49]
	40 mm 1.57"	Thickness 5.1 0.20" 69 2.72" 2 m 6.6" Free-cut (ø2.2) (ø0.09") -40 to +50°C (-40 to +122°F)		MEGA : 3600 141.73" FINE : 3600 141.73"	ULTRA : 3600 141.73" SUPER : 3600 141.73" TURBO : 3600 141.73" HSP : 2500 98.43"	40×3	FU-E40 Approx. 30 g	[P.49]

*1 When using the FS-N Series, "3600 mm 141.73" is assumed as maximum because the fiber cable has a length of 2 m 6.6".
*2 R10 for the first 10 mm of cable from the housing.

Slit for FU-E40 (sold separately)

Model	With OP-84365 attached	With OP-84366 attached
Beam size	30x0.5 mm 1.18 x 0.02"	20x0.5 mm 0.79 x 0.02"
Detecting distance by power mode (mm)*1	MEGA	3600 141.73"
	ULTRA	2100 82.68"
	SUPER	900 35.43"
	TURBO	450 17.72"
	FINE	250 9.84"
	HSP	-
Weight (pair)	Approx. 4 g	



*1 When using the FS-N Series, "3600 mm 141.73" is assumed as maximum because the fiber cable has a length of 2 m 6.6".

Thrubeam Lens Options

Type	Ambient temperature / Appearance (mm)	Model / Weight	Dimensions	Applicable fiber units	Detecting distance (mm)*1					
					MEGA	ULTRA	SUPER	TURBO	FINE	HSP
Ultra-long detecting distance Small-field Aperture Angle: Approx. 8°	-40 to +70°C (-40 to +158°F) Tip: ø4.3 ø0.17" 9.5 0.37"	F-4 Approx. 1 g	Set of 2 [P.50]	FU-77TZ/77V/77	3600 mm 141.73"					2700 mm 106.30"
				FU-7F	3600 mm 141.73"					3200 mm 125.98"
				FU-78	3600 mm 141.73"					2200 mm 86.61"
				FU-77G/77TG	1800 mm 70.87"					
Long detecting Aperture Angle: Approx. 15°	-40 to +300°C (-40 to +572°F) Tip: ø4 ø0.16" 7.9 0.31"	F-2 Approx. 2 g	Set of 2 [P.50]	FU-77TZ/77V/77/84C/88K	3600 mm 141.73"					2100 mm 82.68"
				FU-7F/86A	3600 mm 141.73"					2500 mm 98.43"
				FU-86Z	3600 mm 141.73"					1900 mm 74.80"
				FU-78	3600 mm 141.73"				3300 mm 129.92"	1600 mm 62.99"
				FU-77G/77TG	1800 mm 70.87"					
With mounting holes Side view	-40 to +105°C (-40 to +221°F) Locking Nut 9.3 0.37" 5.6 0.22" 16.7 0.66"	F-5 Approx. 10 g	Set of 2 [P.50]	FU-77V/77	3600 mm 141.73"					2600 mm 102.36"
				FU-7F/86A	3600 mm 141.73"					3100 mm 122.05"
				FU-86Z	3600 mm 141.73"					2900 mm 114.17"
				FU-78	3600 mm 141.73"					2300 mm 90.55"
				FU-77G	1800 mm 70.87"					
Side view	-40 to +70°C (-40 to +158°F)*2 Tip: ø4 ø0.16" 9.5 0.37"	F-1 Approx. 2 g	Set of 2 [P.50]	FU-77V/77	3600 mm 141.73"	3100 mm 122.05"	1900 mm 74.80"	1300 mm 51.18"	900 mm 35.43"	530 mm 20.87"
				FU-77G	1800 mm 70.87"			1300 mm 51.18"	900 mm 35.43"	530 mm 20.87"
				FU-7F/86A	3600 mm 141.73"		3100 mm 122.05"	2100 mm 82.68"	1300 mm 51.18"	630 mm 24.80"
				FU-86Z	3600 mm 141.73"	3300 mm 129.92"	2300 mm 90.55"	1500 mm 59.06"	1100 mm 43.31"	500 mm 19.69"
				FU-78/84C/88K	3200 mm 125.98"	2500 mm 98.43"	1600 mm 62.99"	1100 mm 43.31"	800 mm 31.50"	360 mm 14.17"

*1 3600 mm (1800 mm) 141.73" (70.87") is assumed as maximum because the fiber cable has a length of 2 m (1 m) 6.6" (3.3).
*2 When using the F-1 at a temperature of 70°C (158°F) or more, specify the "Heat-resistant F-1." "Heat-resistant F-1" must be used in a constant temperature.

Reflective model Standard/Simple Mounting Type

Threaded and Hex-shaped Fibers

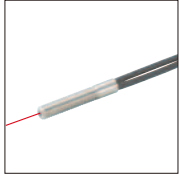

Threaded fibers must be mounted onto brackets before use.

Size/Shape	Detecting Arrangement	Fiber unit length (Diameter) Ambient temperature Appearance (mm)	Cable bend radius (mm)	Detecting distance (mm) ^{*1}		Minimum detectable object (mm) ^{*2}	Model / Weight	Dimensions		
				MEGA FINE	Other power modes					
M3	Hex-shaped	1 m 3.3' Free-cut (ø1.3 ø0.05" x2) (-40 to +50°C (-40 to +122°F))		R2 R0.08" ToughFlex	MEGA : 400 15.75' FINE : 70 2.76"	ULTRA : 270 10.63' SUPER : 170 6.69' TURBO : 110 4.33' HSP : 32 1.26"	FU-35TZ Approx. 7 g	[P.45]		
		1 m 3.3' Free-cut (ø1.3 ø0.05" x2) (-40 to +50°C (-40 to +122°F))			MEGA : 450 17.72' FINE : 72 2.83"	ULTRA : 290 11.42' SUPER : 190 7.48' TURBO : 115 4.53' HSP : 36 1.42"	FU-35FZ Approx. 6 g	[P.45]		
	Threaded	Coaxial	1 m 3.3' Free-cut (ø1.3 ø0.05" x2) Spiral 30 cm 11.81' 0.71" 18 (-40 to +50°C (-40 to +122°F))		R10 R0.39" Stainless Steel	Lens attachment [P.36]	MEGA : 550 21.65' FINE : 110 4.33"	ULTRA : 400 15.75' SUPER : 250 9.84' TURBO : 160 6.30' HSP : 45 1.77"	FU-35FG Approx. 15 g	[P.45]
			1 m 3.3' Free-cut (ø1.3 ø0.05" x2) (-40 to +70°C (-40 to +158°F))		R25 R0.98"	Lens attachment [P.36]	MEGA : 550 21.65' FINE : 110 4.33"	ULTRA : 400 15.75' SUPER : 250 9.84' TURBO : 160 6.30' HSP : 45 1.77"	FU-35FA Approx. 6 g	[P.45]
		50 cm 19.69' cut not allowed FU-21X: -40 to +70°C (-40 to +158°F) FU-24X: -40 to +50°C (-40 to +122°F)		R10 R0.39"	Lens attachment [P.36]	MEGA : 130 5.12' FINE : 36 1.42"	ULTRA : 90 3.54' SUPER : 54 2.13' TURBO : 40 1.57' HSP : 23 0.91"	FU-21X Approx. 4 g	[P.44]	
M4	Hex-shaped	2 m 6.6' Free-cut (ø1.3 ø0.05" x2) (-40 to +50°C (-40 to +122°F))		R2 R0.08" ToughFlex	MEGA : 640 25.20' FINE : 140 5.51"	ULTRA : 420 16.54' SUPER : 320 12.60' TURBO : 220 8.66' HSP : 70 2.76"	FU-66TZ Approx. 10 g	[P.47]		
		2 m 6.6' Free-cut (ø1.3 ø0.05" x2) FU-66Z: -40 to +50°C (-40 to +122°F) FU-66: -40 to +70°C (-40 to +158°F)			R25 R0.98"	MEGA : 770 30.32' FINE : 190 7.48"	ULTRA : 560 22.05' SUPER : 380 14.96' TURBO : 260 10.24' HSP : 80 3.15"	FU-66Z Approx. 10 g	[P.47]	
M6	Hex-shaped	2 m 6.6' Free-cut (ø2.2 ø0.09" x2) (-40 to +50°C (-40 to +122°F))		R2 R0.98" ToughFlex	MEGA : 710 27.95' FINE : 210 8.27"	ULTRA : 550 21.65' SUPER : 470 18.50' TURBO : 310 12.20' HSP : 90 3.54"	ø0.005 ø0.0002" Gold wire	FU-67TZ Approx. 32 g	[P.47]	
		1 m 3.3' cut not allowed (-40 to +50°C (-40 to +122°F))								R10 R0.39" Stainless Steel
	Threaded	Coaxial	1 m 3.3' cut not allowed (-40 to +50°C (-40 to +122°F))		R10 R0.39" Stainless Steel	Lens attachment [P.36]	MEGA : 400 15.75' FINE : 70 2.76"	ULTRA : 270 10.63' SUPER : 170 6.69' TURBO : 110 4.33' HSP : 32 1.26"	FU-35TG Approx. 32 g	[P.45]
			2 m 6.6' Free-cut (ø2.2 ø0.09" x2) (-40 to +50°C (-40 to +122°F))		R0.5 R0.02" ToughFlex	MEGA : 900 35.43' FINE : 210 8.27"	ULTRA : 740 29.13' SUPER : 490 19.29' TURBO : 320 12.60' HSP : 110 4.33"	FU-67V Approx. 25 g	[P.47]	
		Parallel	2 m 6.6' Free-cut (ø2.2 ø0.09" x2) (-40 to +50°C (-40 to +122°F))		R2 R0.08" ToughFlex	MEGA : 1200 47.24' FINE : 300 11.81"	ULTRA : 900 35.43' SUPER : 590 23.23' TURBO : 430 16.93' HSP : 140 5.51"	FU-61Z Approx. 22 g	[P.47]	
			2 m 6.6' Free-cut (ø2.2 ø0.09" x2) (-40 to +50°C (-40 to +122°F))		R2 R0.08" ToughFlex	MEGA : 900 35.43' FINE : 210 8.27"	ULTRA : 740 29.13' SUPER : 490 19.29' TURBO : 320 12.60' HSP : 110 4.33"	FU-67 Approx. 21 g	[P.47]	
			1 m 3.3' cut not allowed (-40 to +50°C (-40 to +122°F))		R10 R0.39" Stainless Steel	MEGA : 900 35.43' FINE : 210 8.27"	ULTRA : 740 29.13' SUPER : 490 19.29' TURBO : 320 12.60' HSP : 110 4.33"	FU-67G Approx. 29 g	[P.47]	
			2 m 6.6' Free-cut (ø2.2 ø0.09" x2) (-40 to +70°C (-40 to +158°F))		R25 R0.98"	MEGA : 1300 51.18' FINE : 380 14.96"	ULTRA : 1000 39.37' SUPER : 820 32.28' TURBO : 500 19.69' HSP : 160 6.30"	FU-61 Approx. 21 g	[P.47]	
		2 m 6.6' Free-cut (ø2.2 ø0.09" x2) (-40 to +158°F)		R25 R0.98"	MEGA : 1100 43.31' FINE : 300 11.81"	ULTRA : 860 33.86' SUPER : 570 22.44' TURBO : 410 16.14' HSP : 140 5.51"	FU-6F Approx. 21 g	[P.47]		
		Coaxial	2 m 6.6' Free-cut (ø2.2 ø0.09" x2) (-40 to +70°C (-40 to +158°F))		R25 R0.98"	MEGA : 720 28.35' FINE : 160 6.30"	ULTRA : 630 24.80' SUPER : 410 16.14' TURBO : 270 10.63' HSP : 130 5.12"	FU-25 Approx. 18 g	[P.44]	

*1 When using the FS-N Series. Standard target: White mat paper (Reflective type only.)

*2 The smallest detectable object was determined at the optimal detecting distance and sensitivity setting.

See P.36 for specifications when a reflective lens is attached.

Cylindrical (Set Screw Installation)

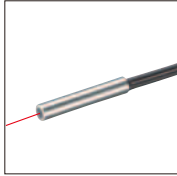

Installed by drilling a hole and using a set screw. Suitable for installation in locations where space is limited.

Size	Fiber unit length (Diameter) Ambient temperature Appearance (mm)	Cable bend radius (mm)	Detecting distance (mm) ^{*1}		Minimum detectable object (mm) ^{*2}	Model / Weight	Dimensions
			MEGA FINE	Other power modes			
ø1.5 ø0.06"	1 m 3.3' cut not allowed -40 to +70°C (-40 to +158°F) 	R4 R0.16" High-flex	MEGA : 150 5.91" FINE : 32 1.26"	ULTRA : 100 3.94" SUPER : 80 3.15" TURBO : 54 2.13" HSP : 22 0.87"	ø0.005 ø0.0002" Gold wire	FU-49X Approx. 3 g	[P.46]
	1 m 3.3' cut not allowed -40 to +70°C (-40 to +158°F) 	R10 R0.39"	MEGA : 27 1.06" FINE : 4.8 0.19"	ULTRA : 18 0.71" SUPER : 13 0.51" TURBO : 10 0.39" HSP : 2.4 0.09"		FU-46 Approx. 2 g	[P.46]
ø2 ø0.08"	1 m 3.3' Free-cut (ø1.0 ø0.04" x2) -40 to +50°C (-40 to +122°F) 	R2 R0.08" ToughFlex High-flex	MEGA : 140 5.51" FINE : 40 1.57"	ULTRA : 110 4.33" SUPER : 80 3.15" TURBO : 54 2.13" HSP : 13 0.51"	FU-49U Approx. 4 g	[P.46]	
ø2.5 ø0.10"	50 cm 19.69' cut not allowed -40 to +70°C (-40 to +158°F) 	R25 R0.98"	MEGA : 72 2.83" FINE : 23 0.91"	ULTRA : 59 2.32" SUPER : 45 1.77" TURBO : 32 1.26" HSP : 12 0.47"	FU-22X Approx. 4 g	[P.44]	
	2 m 6.6' Free-cut (ø1.3 ø0.05" x2) FU-4FZ: -40 to +50°C (-40 to +122°F) FU-4F: -40 to +70°C (-40 to +158°F) 	R2 R0.08" ToughFlex	MEGA : 770 30.32" FINE : 190 7.48"	ULTRA : 560 22.05" SUPER : 380 14.96" TURBO : 260 10.24" HSP : 80 3.15"	FU-4FZ Approx. 8 g	[P.45]	
ø3 ø0.12"	1 m 3.3' Free-cut (ø1.0 ø0.04" x2) -40 to +50°C (-40 to +122°F) 	R2 R0.08" ToughFlex High-flex	MEGA : 140 5.51" FINE : 40 1.57"	ULTRA : 110 4.33" SUPER : 80 3.15" TURBO : 60 2.36" HSP : 13 0.51"	FU-4F Approx. 8 g	[P.45]	
	2 m 6.6' Free-cut (ø1.0 ø0.04" x2) -40 to +70°C (-40 to +158°F) 	R4 R0.16" High-flex	MEGA : 290 11.42" FINE : 63 2.48"	ULTRA : 200 7.87" SUPER : 130 5.12" TURBO : 80 3.15" HSP : 32 1.26"	FU-48U Approx. 4 g	[P.46]	
	50 cm 19.69' cut not allowed -40 to +70°C (-40 to +158°F) 	R25 R0.98"	MEGA : 830 32.68" FINE : 180 7.09"	ULTRA : 680 26.77" SUPER : 470 18.50" TURBO : 320 12.60" HSP : 130 5.12"	FU-48 Approx. 7 g	[P.46]	
	50 cm 19.69' cut not allowed -40 to +70°C (-40 to +158°F) 	R25 R0.98"	MEGA : 830 32.68" FINE : 180 7.09"	ULTRA : 680 26.77" SUPER : 470 18.50" TURBO : 320 12.60" HSP : 130 5.12"	FU-23X Approx. 4 g	[P.44]	
	50 cm 19.69' cut not allowed -40 to +70°C (-40 to +158°F) 	R4 R0.16"	MEGA : 68 2.68" FINE : 18 0.71"	ULTRA : 54 2.13" SUPER : 40 1.57" TURBO : 27 1.06" HSP : 8 0.32"	FU-45X Approx. 4 g	[P.46]	
	50 cm 19.69' cut not allowed -40 to +70°C (-40 to +158°F) 	R4 R0.16"	MEGA : 68 2.68" FINE : 18 0.71"	ULTRA : 54 2.13" SUPER : 40 1.57" TURBO : 27 1.06" HSP : 8 0.32"	FU-45X Approx. 4 g	[P.46]	

*1 When using the FS-N Series. Standard target: White mat paper (Reflective type only.)
*2 The smallest detectable object was determined at the optimal detecting distance and sensitivity setting.

Integrated Bracket

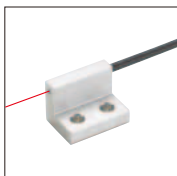

The bracket and sensor are integrated.

Beam emitting direction	Optical axis height	Fiber unit length (Diameter) Ambient temperature Appearance (mm)	Cable bend radius (mm)	Detecting distance (mm) ^{*1}		Minimum detectable object (mm) ^{*2}	Model / Weight	Dimensions
				MEGA FINE	Other power modes			
Top	10 mm 0.39"	2 m 6.6' Free-cut (ø2.2) (ø0.09") -40 to +50°C (-40 to +122°F) 	R2 R0.08" ToughFlex	MEGA : 760 29.92" FINE : 170 6.69"	ULTRA : 580 22.83" SUPER : 430 16.93" TURBO : 320 12.60" HSP : 90 3.54"	ø0.005 ø0.0002"	FU-L41Z Approx. 25 g	[P.50]

*1 When using the FS-N Series. Standard target: White mat paper (Reflective type only.)
*2 The smallest detectable object was determined at the optimal detecting distance and sensitivity setting.

Benefits!

Eliminate concerns about bracket design, bracket and sensor assembly, or loose brackets. Integrated designs reduce space requirements.

Reflective model **Small Spot/Focused Beam Type**

Small Spot Reflective



Great for small object detection.

Adjustable Beam Spot/Built-in Lens Fiber Unit

Type	Spot diameter (mm)	Focal distance (mm)	Fiber unit length (Diameter) Ambient temperature Appearance (mm)	Model / Weight	Minimum bend radius (mm)	Dimensions
Adjustable beam spot	ø0.9 to 3.5 ø0.04" to ø0.14"	10 to 30 0.39" to 1.18"	2 m 6.6' Free-cut (ø1.3 ø0.05" x2) -40 to +70°C (-40 to +158°F) 	FU-10 Approx. 5 g	R25 R0.98"	[P.44]

Adjustable Beam Spot/Lens + Fiber Unit

Type	Spot diameter (mm)	Focal distance (mm)	Lens			Dimensions	Fiber Unit		Dimensions
			Appearance (mm)	Weight	Model		Minimum bend radius (mm) Appearance	Model	
Side view Adjustable beam spot	ø0.5 to 3 ø0.02" to ø0.12"	8 to 30 0.32" to 1.18"		Approx. 2 g	F-5HA	[P.50]	R2 R0.08" ToughFlex R10 R0.39" Stainless Steel R25 R0.98"	FU-35FZ FU-35FG FU-35FA	[P.51]

Parallel Beam Spot/Lens + Fiber Unit

Type	Spot diameter (mm)	Lens		Dimensions	Fiber Unit		Detecting distance (mm)*1		Dimensions
		Appearance (mm)	Weight		Model	Minimum bend radius (mm) Appearance	Model	MEGA FINE	
Parallel beam	Approx. ø4 ø0.16" (at 0 to 20 mm 0" to 0.79" distance)	Ambient temperature: -30 to +70°C (-22 to +158°F) Tip: ø4.3 ø0.17" 9.5 0.37" Approx. 2 g	F-3HA	[P.50]	R2 R0.08" ToughFlex	FU-35FZ	MEGA : 45 1.77" FINE : 36 1.42"	ULTRA : 45 1.77" SUPER : 45 1.77" TURBO : 40 1.57" HSP : 27 1.06"	[P.51]
					R10 R0.39" Stainless steel	FU-35FG	MEGA : 65 2.56" FINE : 54 2.13"	ULTRA : 65 2.56" SUPER : 65 2.56" TURBO : 60 2.36" HSP : 45 1.77"	
					R25 R0.98"	FU-35FA	MEGA : 40 1.57" FINE : 27 1.06"	ULTRA : 40 1.57" SUPER : 40 1.57" TURBO : 32 1.26" HSP : 23 0.91"	
					R2 R0.08" ToughFlex	FU-35TZ			
					R10 R0.39" Stainless Steel	FU-35TG			

*1 When using the FS-N Series. Standard target: White mat paper (Reflective type only.)

Small Beam Spot/Lens + Fiber Unit

Type	Spot diameter (mm)	Focal distance (mm)	Lens			Dimensions	Fiber Unit		Dimensions			
			Appearance (mm)	Weight	Model		Minimum bend radius (mm) Appearance	Model				
Small spot	Approx. ø0.1 ø0.004"	7±2 0.28"±0.08"	Ambient temperature: -30 to +70°C (-22 to +158°F) Tip: ø4.3 ø0.17" 15.6 0.61" Approx. 1 g	F-2HA	[P.50]	R10 R0.39"	FU-24X	[P.51]				
	Approx. ø0.2 ø0.008"					R25 R0.98"	FU-21X					
	Approx. ø0.4 ø0.016"					R2 R0.08" ToughFlex	FU-35FZ					
						R10 R0.39" Stainless Steel	FU-35FG					
	Approx. ø0.5 ø0.02"					R25 R0.98"	FU-35FA					
						R2 R0.08" ToughFlex	FU-35TZ					
	Approx. ø0.5 ø0.02"	15±2 0.59"±0.08"	Ambient temperature: -30 to +70°C (-22 to +158°F) Tip: ø7.4 ø0.29" 27 1.06" Approx. 2 g	F-4HA	[P.50]	R2 R0.08" ToughFlex	FU-35FZ					
		Approx. ø1.0 ø0.04"				R10 R0.39" Stainless Steel	FU-35FG					
						Approx. ø2.0 ø0.08"	R2 R0.08" ToughFlex		FU-35TZ			
		35±3 1.38"±0.12"					R10 R0.39" Stainless Steel		FU-35TG			
						Approx. ø0.1 ø0.004"	5 0.20"		Ambient temperature: -40 to +70°C (-40 to +158°F) Tip: ø10.6 ø0.42" 26 1.02" Approx. 5 g	F-6HA	[P.50]	R25 R0.98"
		Approx. ø0.2 ø0.08"					R2 R0.08" ToughFlex					FU-35FZ
Approx. ø0.4 ø0.016"	7±2 0.28"±0.08"		Ambient temperature: -30 to +70°C (-22 to +158°F) Tip: ø4.3 ø0.17" 15.6 0.61" Approx. 1 g	F-2HA	[P.50]	R10 R0.39" Stainless Steel	FU-35TG					
		R25 R0.98"				FU-35FA						

Small Beam Spot/Built-in Lens Fiber Unit

Type	Spot diameter (mm)	Focal distance (mm)	Fiber unit length (Diameter) Ambient temperature Appearance (mm)	Model / Weight	Minimum bend radius (mm)	Dimensions
Small spot	Approx. ø0.1 ø0.004"	5 0.20"	50 cm 19.69' cut not allowed -40 to +70°C (-40 to +158°F) 	FU-20 Approx. 2 g	R25 R0.98"	[P.44]

* Cannot be used with the FS-N Series HIGH SPEED mode.

Reflective/Small Spot/Focused Beam Type

Focused Beam/ High power

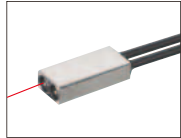

Use of a lens reduces beam width and helps avoid deflection.

Beam emitting direction	Aperture angle	Fiber unit length (Diameter) Ambient temperature Appearance (mm)	Cable bend radius (mm)	Detecting distance (mm) ^{*1}		Minimum detectable object (mm) ^{*2}	Model / Weight	Dimensions
				MEGA FINE	Other power modes			
Top	Approx. 8°	2 m 6.6' Free-cut (ø2.2 ø0.09" x2) -40 to +50°C (-40 to +122°F) Thickness 5.2 0.20"	R2 R0.08" ToughFlex	MEGA : 30 to 2300 FINE : 30 to 290	ULTRA : 30 to 1600 SUPER : 30 to 760 TURBO : 30 to 410 HSP : 30 to 160	ø0.3 ø0.01" Copper wire (vertical)	FU-40 Approx. 23 g	[P.45]
		1 m 3.3' cut not allowed -40 to +50°C (-40 to +122°F) Thickness 5.2 0.20"	R10 R0.39" Stainless Steel	MEGA : 30 to 2300 FINE : 30 to 290	ULTRA : 30 to 1600 SUPER : 30 to 760 TURBO : 30 to 410 HSP : 30 to 160		FU-40G Approx. 50 g	[P.45]

*1 When using the FS-N Series. Standard target: White mat paper (Reflective type only).
*2 The smallest detectable object was determined at the optimal detecting distance and sensitivity setting.

Reflective model Transparent object detection type

Definite-reflective

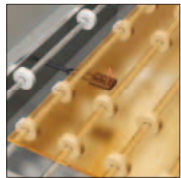

Features a limited detection range.

Benefits!

Thin size allows installation where space is limited. Since the effects of the background are minimized, stable detection is possible in complex environments. The FU-38 is a small spot type, which is great for small object detection.

Beam emitting direction	Fiber unit length (Diameter) Ambient temperature Appearance (mm)	Cable bend radius (mm)	Detecting distance (mm) ^{*1}		Spot diameter (mm)	Minimum detectable object (mm) ^{*2}	Model / Weight	Dimensions
			MEGA FINE	Other power modes				
Top	2 m 6.6' Free-cut (ø2.2 ø0.09" x2) -40 to +70°C (-40 to +158°F) Thickness 5.2 0.20"	R25 R0.98"	MEGA : 15 to 70 FINE : 15 to 30	ULTRA : 15 to 60 SUPER : 15 to 46 TURBO : 15 to 38 HSP : -	-	-	FU-40S Approx. 25 g	[P.45]
Side	2 m 6.6' Free-cut (ø1.0 ø0.04" x2) -40 to +70°C (-40 to +158°F) Thickness 5.0 0.20"	R10 R0.39"	MEGA : 3.0 FINE : 3.0	ULTRA : 3.0 SUPER : 3.0 TURBO : 3.0 HSP : 3.0	Approx. 4.5 ø0.18" (At 3.0 0.12" mm distance)	ø0.005 ø0.0002" Gold wire	FU-37 Approx. 6 g	[P.45]
Flat	2 m 6.6' Free-cut (ø1.0 ø0.04" x2) -40 to +70°C (-40 to +158°F) Thickness 4.0 0.16"	R10 R0.39"	MEGA : 6.0 FINE : 6.0	ULTRA : 6.0 SUPER : 6.0 TURBO : 6.0 HSP : 6.0	Approx. ø1.5 ø0.06" (At 6.0 0.24" mm distance)	-	FU-38 Approx. 5 g	[P.45]
	2 m 6.6' Free-cut (ø1.0 ø0.04" x2) -40 to +70°C (-40 to +158°F) Thickness 4.3 0.17"	R10 R0.39"	MEGA : 0 to 4 FINE : 0 to 4	ULTRA : 0 to 4 SUPER : 0 to 4 TURBO : 0 to 4 HSP : 2±1.4	-	ø0.08 ø0.003" Copper wire	FU-38V Approx. 5 g	[P.45]
Flat	2 m 6.6' Free-cut (ø2.2 ø0.09" x2) -40 to +60°C (-40 to +140°F) Thickness 5.2 0.20"	R25 R0.98"	MEGA : 8 to 38 FINE : 8 to 32	ULTRA : 8 to 36 SUPER : 8 to 35 TURBO : 8 to 34 HSP : 10 to 26	-	-	FU-38L Approx. 20 g	[P.45]
	2 m 6.6' Free-cut (ø2.2 ø0.09" x2) -40 to +70°C (-40 to +158°F) Thickness 3.6 0.14"	R5 R0.20"	MEGA : 0 to 25 FINE : 0 to 25	ULTRA : 0 to 25 SUPER : 0 to 25 TURBO : 0 to 25 HSP : -	-	-	FU-38S Approx. 20 g	[P.45]
Flat	2 m 6.6' Free-cut (ø1.0 ø0.04" x2) -40 to +70°C (-40 to +158°F) Thickness 3.8 0.15"	R25 R0.98"	MEGA : 0 to 14 FINE : 0 to 14	ULTRA : 0 to 14 SUPER : 0 to 14 TURBO : 0 to 14 HSP : 0 to 12	-	-	FU-38R Approx. 20 g	[P.45]

*1 When using the FS-N Series. Standard target: White mat paper (Reflective type only).
*2 The smallest detectable object was determined at the optimal detecting distance and sensitivity setting.

Reflective model Space-Saving Type

FlatB racket Fibers

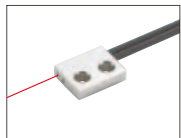

Bracket-shaped design is thinner than ever.

Benefits!

Metal housing eliminates concern about damaged sensors. The sensor and case form a flat surface, so there are no openings where dust and other foreign matter can enter.

Beam emitting direction	Fiber unit length (Diameter) Ambient temperature Appearance (mm)	Cable bend radius (mm)	Detecting distance (mm) ^{*1}		Minimum detectable object (mm) ^{*2}	Model / Weight	Dimensions
			MEGA FINE	Other power modes			
Top	1 m 3.3' Free-cut (ø1.0 ø0.04" x2) -40 to +50°C (-40 to +122°F) Thickness 2.0 0.08"	R2 R0.08" ToughFlex	MEGA : 1 to 160 FINE : 1 to 36	ULTRA : 1 to 120 SUPER : 1 to 81 TURBO : 1 to 60 HSP : 1 to 13	ø0.005 ø0.0002" Gold wire	FU-44TZ Approx. 3 g	[P.46]
Side	1 m 3.3' Free-cut (ø1.0 ø0.04" x2) -40 to +50°C (-40 to +122°F) Thickness 2.5 0.10"	R2 R0.08" ToughFlex	MEGA : 1 to 160 FINE : 1 to 36	ULTRA : 1 to 120 SUPER : 1 to 81 TURBO : 1 to 60 HSP : 1 to 18		FU-47TZ Approx. 4 g	[P.45]
Flat	1 m 3.3' Free-cut (ø1.0 ø0.04" x2) -40 to +50°C (-40 to +122°F) Thickness 2.0 0.08"	R2 R0.08" ToughFlex	MEGA : 2 to 120 FINE : 2 to 24	ULTRA : 2 to 77 SUPER : 2 to 50 TURBO : 2 to 32 HSP : 2 to 8	FU-41TZ Approx. 5 g	[P.45]	
	2 m 6.6' Free-cut (ø2.2 ø0.09" x2) -40 to +50°C (-40 to +122°F) Thickness 4.0 0.16"	R2 R0.08" ToughFlex	MEGA : 1 to 500 FINE : 1 to 70	ULTRA : 1 to 320 SUPER : 1 to 190 TURBO : 1 to 130 HSP : 1 to 50	FU-42TZ Approx. 24 g	[P.45]	

*1 When using the FS-N Series. Standard target: White mat paper (Reflective type only).
*2 The smallest detectable object was determined at the optimal detecting distance and sensitivity setting.

Sleeve

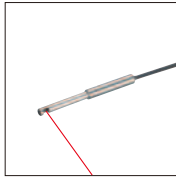

The fiber tip is incorporated into a thin sleeve.

Benefits!

When determining the smallest detectable object, positioning the sensor too closely to the object causes the object to disappear, making alignment difficult. With the sleeve type, the sensor itself does not become an obstruction and alignment is much easier.

Beam emitting direction	Fiber unit length (Diameter) Ambient temperature Appearance (mm)	Cable bend radius (mm)	Detecting distance (mm) ^{*1}		Minimum detectable object (mm) ^{*2}	Model / Weight	Dimensions
			MEGA FINE	Other power modes			
Side	2 m 6.6' Free-cut (ø1.0 ø0.04" x2) -40 to +70°C (-40 to +158°F) Sleeve part Do not bend	R10 R0.39"	MEGA : 180 7.09" FINE : 32 1.26"	ULTRA : 130 5.12" SUPER : 81 3.19" TURBO : 50 1.97" HSP : 18 0.71"	ø0.005 ø0.0002" Gold wire	FU-31 Approx. 5 g	[P.44]
	1 m 3.3' Free-cut (ø2.2 ø0.09" x2) -40 to +70°C (-40 to +158°F) Sleeve part Do not bend	R25 R0.98"	MEGA : 320 12.60" FINE : 45 1.77"	ULTRA : 250 9.84" SUPER : 140 5.51" TURBO : 90 3.54" HSP : 32 1.26"		FU-33 Approx. 10 g	[P.44]
Top	50 cm 19.69' cut not allowed -40 to +70°C (-40 to +158°F) Sleeve part Do not bend	R4 R0.16"	MEGA : 68 2.68" FINE : 18 0.71"	ULTRA : 54 2.13" SUPER : 40 1.57" TURBO : 27 1.06" HSP : 8 0.32"		FU-65X Approx. 5 g	[P.47]
	2 m 6.6' Free-cut (ø1.3 ø0.05" x2) -40 to +50°C (-40 to +122°F) Sleeve part Do not bend	R2 R0.08" ToughFlex	MEGA : 290 11.42" FINE : 54 2.13"	ULTRA : 190 7.48" SUPER : 120 4.72" TURBO : 80 3.15" HSP : 23 0.91"		FU-63Z Approx. 10 g	[P.47]
	2 m 6.6' Free-cut (ø1.3 ø0.05" x2) -40 to +70°C (-40 to +158°F) Sleeve part Do not bend	R25 R0.98"	MEGA : 330 12.99" FINE : 72 2.83"	ULTRA : 230 9.06" SUPER : 150 5.91" TURBO : 100 3.94" HSP : 36 1.42"		FU-63 Approx. 10 g	[P.47]
	2 m 6.6' Free-cut (ø1.3 ø0.05" x2) -40 to +70°C (-40 to +158°F) Sleeve part Do not bend	R25 R0.98"	MEGA : 330 12.99" FINE : 72 2.83"	ULTRA : 230 9.06" SUPER : 150 5.91" TURBO : 100 3.94" HSP : 36 1.42"		FU-63T Approx. 10 g	[P.47]
	50 cm 19.69' cut not allowed -40 to +70°C (-40 to +158°F) Sleeve part Do not bend	R4 R0.16"	MEGA : 68 2.68" FINE : 18 0.71"	ULTRA : 54 2.13" SUPER : 40 1.57" TURBO : 27 1.06" HSP : 8 0.32"		FU-45X Approx. 4 g	[P.46]
	2 m 6.6' Free-cut (ø1.3 ø0.05" x2) ø1.6" ø4 -40 to +70°C (-40 to +158°F) Sleeve part Do not bend	R25 R0.98"	MEGA : 330 12.99" FINE : 72 2.83"	ULTRA : 230 9.06" SUPER : 150 5.91" TURBO : 100 3.94" HSP : 36 1.42"		FU-43 Approx. 8 g	[P.46]
	1 m 3.3' cut not allowed -40 to +70°C (-40 to +158°F) Sleeve part Do not bend	R10 R0.39"	MEGA : 27 1.06" FINE : 4.8 0.19"	ULTRA : 18 0.71" SUPER : 13 0.51" TURBO : 10 0.39" HSP : 2.4 0.09"		FU-46 Approx. 2 g	[P.46]
Coaxial narrow beam 10°	50 cm 19.69' cut not allowed -40 to +70°C (-40 to +158°F) Sleeve part Do not bend	R25 R0.98"	MEGA : 72 2.83" FINE : 23 0.91"	ULTRA : 59 2.32" SUPER : 45 1.77" TURBO : 32 1.26" HSP : 12 0.47"		FU-22X Approx. 4 g	[P.44]

*1 When using the FS-N Series. Standard target: White mat paper (Reflective type only).

*2 The smallest detectable object was determined at the optimal detecting distance and sensitivity setting.

Reflective model Environment-proof

Oil-proof, Chemical Proof



Sensor is encased in fluorocarbon resin.

Beam emitting direction	Fiber unit length (Diameter) Ambient temperature Appearance (mm)	Cable bend radius (mm)	Detecting distance (mm) ^{*1}		Standard Detectable object (mm)	Model / Weight	Dimensions
			MEGA FINE	Other power modes			
Top	2 m 6.6' Free-cut (ø1.3 ø0.05" x2) -40 to +70°C (-40 to +158°F) Sleeve part Do not bend	R40 R1.57"	MEGA : 310 12.20" FINE : 140 5.51"	ULTRA : 290 11.42" SUPER : 250 9.84" TURBO : 200 7.87" HSP : 80 3.15"	200x200 7.87" x 7.87" t = 0.7 0.03" Glass substrate	FU-91 Approx. 32 g	[P.48]
	2 m 6.6' Free-cut (ø1.3 ø0.05" x2) -40 to +60°C (-40 to +140°F) Thickness 9.6 0.38" (width of ø4.1 ø0.16" mounting hole seating surface) Sleeve part Do not bend		MEGA : 8 to 20 FINE : 8 to 20	ULTRA : 8 to 20 SUPER : 8 to 20 TURBO : 8 to 20 HSP : 8 to 16		FU-97P NEW Approx. 75 g	[P.49]
	2 m 6.6' Free-cut (ø1.3 ø0.05" x2) -40 to +85°C (-40 to +185°F) Thickness 9 0.35" Sleeve part Do not bend		MEGA : 8 to 20 FINE : 8 to 20	ULTRA : 8 to 20 SUPER : 8 to 20 TURBO : 8 to 20 HSP : 8 to 16		FU-97S NEW Approx. 90 g	[P.49]

*1 When using the FS-N Series. Standard target: White mat paper (Reflective type only).

Reflective/Environment-proof

High-flex



Suited for use with moving object detection.

Size (mm)	Fiber unit length (Diameter) Ambient temperature Appearance (mm)	Cable bend radius (mm)	Detecting distance (mm)*1		Minimum detectable object (mm)*2	Model / Weight	Dimensions
			MEGA FINE	Other power modes			
ø2 ø0.08"	1 m 3.3' Free-cut (ø1.0 ø0.04" x2) -40 to +50°C (-40 to +122°F) ø0.08" ø2	R2 R0.08" ToughFlex High-flex	MEGA : 140 5.51" FINE : 40 1.57"	ULTRA : 110 4.33" SUPER : 80 3.15" TURBO: 60 2.36" HSP : 13 0.51"	ø0.005 ø0.0002" Gold wire	FU-49U Approx. 4 g	[P.46]
ø3 ø0.12"	1 m 3.3' Free-cut (ø1.0 ø0.04" x2) -40 to +50°C (-40 to +122°F) ø0.12" ø3					FU-48U Approx. 4 g	[P.46]
M3	1 m 3.3' Free-cut (ø1.0 ø0.04" x2) -40 to +50°C (-40 to +122°F) M3					FU-69U Approx. 4 g	[P.47]
ø1.5 ø0.06"	1 m 3.3' cut not allowed -40 to +70°C (-40 to +158°F) ø1.5 ø0.06"	R4 R0.16" High-flex	MEGA : 150 5.91" FINE : 32 1.26"	ULTRA : 100 3.94" SUPER : 80 3.15" TURBO: 54 2.13" HSP : 22 0.87"		FU-49X Approx. 3 g	[P.46]
M3	1 m 3.3' cut not allowed -40 to +70°C (-40 to +158°F) M3					FU-69X Approx. 3 g	[P.47]
ø3 ø0.12"	2 m 6.6' Free-cut (ø1.0 ø0.04" x2) -40 to +70°C (-40 to +158°F) ø3					FU-48 Approx. 7 g	[P.46]
M4	2 m 6.6' Free-cut (ø1.0 ø0.04" x2) -40 to +70°C (-40 to +158°F) M4	FU-68 Approx. 8 g	[P.47]				

*1 When using the FS-N Series. Standard target: White mat paper (Reflective type only.)
*2 The smallest detectable object was determined at the optimal detecting distance and sensitivity setting.

Heat Resistant

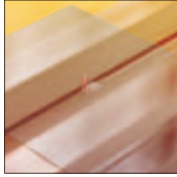

Suited for use at high object detection temperatures of up to 350°C (662°F).

Heat resistant temperature*3	Fiber unit length (Diameter) Ambient temperature Appearance (mm)	Cable bend radius (mm)	Detecting distance (mm)*1		Minimum detectable object (mm)*2	Model / Weight	Dimensions			
			MEGA FINE	Other power modes						
100°C*4 (212°F)	2 m 6.6' Free-cut (ø2.2 ø0.09" x2) -40 to +100°C (-40 to +212°F) M6	R5 R0.20" ToughFlex	MEGA : 740 29.13" FINE : 160 6.30"	ULTRA : 580 22.83" SUPER : 410 16.14" TURBO: 320 12.60" HSP : 90 3.54"	ø0.005 ø0.0002" Gold wire	FU-85Z Approx. 25 g	[P.48]			
105°C*4 (221°F)	2 m 6.6' Free-cut (ø2.2 ø0.09" x2) -40 to +105°C (-40 to +221°F) M6					FU-85A Approx. 21 g	[P.48]			
150°C*5 (302°F)	2 m 6.6' Free-cut (ø2.2 ø0.09" x2) -40 to +150°C (-40 to +302°F) M6					FU-85H Approx. 35 g	[P.48]			
180°C*5 (356°F)	2 m 6.6' Free-cut (ø2.2 ø0.09" x2) -60 to +180°C (-76 to +356°F) M6	R35 R1.38"	MEGA : 860 33.86" FINE : 200 7.87"	ULTRA : 710 27.95" SUPER : 470 18.50" TURBO: 350 13.78" HSP : 100 3.94"		FU-87 Approx. 33 g	[P.48]			
200°C (392°F)	1 m 3.3' cut not allowed -40 to +200°C (-40 to +392°F) M4					R8 R0.32"	MEGA : 770 30.32" FINE : 190 7.48"	ULTRA : 650 25.59" SUPER : 450 17.72" TURBO: 340 13.39" HSP : 100 3.94"	FU-87K Approx. 15 g	[P.48]
300°C (572°F)	1 m 3.3' cut not allowed -40 to +300°C (-40 to +572°F) ø2.1 ø0.08" M4								R25 R0.98"	MEGA : 650 25.59" FINE : 140 5.51"
350°C (662°F)	1 m 3.3' cut not allowed -40 to +300°C (-40 to +572°F) ø0.10" ø2.6" M4	FU-83C Approx. 23 g	[P.48]							
180°C*6 (356°F)	1 m 3.3' cut not allowed -30 to +350°C (-22 to +662°F) ø0.08" ø2.1 M4	R35 R1.38"	MEGA : 2.5 to 65 FINE : 0.10" to 2.56" 0.10" to 0.63"	ULTRA : 2.5 to 55 0.10" to 2.17" SUPER : 2.5 to 27 0.10" to 1.06" TURBO: 2.5 to 22 0.10" to 0.87" HSP : 2.5 to 10 0.10" to 0.39"	FU-81C Approx. 24 g	[P.48]				
250°C (482°F)	2 m 6.6' Free-cut (ø2.2 ø0.09" x2) -40 to +180°C (-40 to +356°F) ø0.75" Thickness 5 0.20" M6				R25 R0.98"	MEGA : 8 to 37 FINE : 0.32" to 1.46" 0.32" to 1.18"	ULTRA : 8 to 34 0.32" to 1.34" SUPER : 8 to 32 0.32" to 1.26" TURBO: 8 to 30 0.32" to 1.18" HSP : 10 to 18 0.39" to 0.71"	FU-38H Approx. 45 g	[P.45]	
	1 m 3.3' cut not allowed -40 to +250°C (-40 to +482°F) ø0.75" Thickness 5 0.20" M6							FU-38K Approx. 45 g	[P.45]	
	2 m 6.6' cut not allowed -40 to +250°C (-40 to +482°F) ø0.67" Thickness 5 0.20" M6				FU-38LK Approx. 70 g	[P.45]				

*1 When using the FS-N Series. Standard target: White mat paper (Reflective type only). (FU-38LK shows values for t=0.7 mm 0.03" glass substrate (horizontal direction).)

*2 The smallest detectable object was determined at the optimal detecting distance and sensitivity setting.

*3 Use the fiberoptic sensor under dry conditions. Allow some margin for the temperature upper limit when selecting a heat-resistant fiber unit.

*4 The recommended maximum ambient temperature during operation is 90°C (194°F) when constantly using a fiber unit in a high-temperature environment.

*5 The recommended maximum ambient temperature during operation is 130°C (266°F) when constantly using a fiber unit in a high-temperature environment.

*6 The recommended maximum ambient temperature during operation is 150°C (302°F) when constantly using a fiber unit in a high-temperature environment.

Reflective model Dedicated application type

Area



Useful in situations where target position varies.

Type	Detecting width	Fiber unit length (Diameter)		Cable bend radius (mm)	Detecting distance (mm)*1		Minimum detectable object (mm)*2	Model / Weight	Dimensions
		Ambient temperature	Appearance (mm)		MEGA FINE	Other power modes			
Array	10 mm 0.39" (Detecting distance is 4 mm 0.16")	2 m 6.6' Free-cut (ø2.2 ø0.09" x2) -40 to +70°C (-40 to +158°F)	20 0.79" x 20 0.79" Thickness 4 0.16"	R4+3 R0.16"	MEGA : 740 29.13" FINE : 140 5.51"	ULTRA : 460 18.11" SUPER : 260 10.24" TURBO : 180 7.09" HSP : 60 2.36"	ø0.005 ø0.0002" Gold wire	FU-A05D	[P.49]
	15 mm 0.59" (Detecting distance is 4 mm 0.16")	2 m 6.6' Free-cut (ø2.2 ø0.09" x2) -40 to +70°C (-40 to +158°F)	20 0.79" x 20 0.79" Thickness 4 0.16"					FU-A10D	[P.49]
Area	15 mm 0.59" (At detecting distance of 15 mm 0.59")	2 m 6.6' Free-cut (ø2.2 ø0.09" x2) -40 to +70°C (-40 to +158°F)	15 0.59" x 7 0.28" x 28 1.10"	R25 R0.98"	MEGA : 5 to 200 0.20" to 7.87" FINE : 5 to 140 0.20" to 5.51"	ULTRA : 5 to 200 0.20" to 7.87" SUPER : 5 to 200 0.20" to 7.87" TURBO : 5 to 160 0.20" to 6.30" HSP : 5 to 110 0.20" to 4.33"	ø0.1 ø0.004" Gold wire	FU-11	[P.44]

*1 When using the FS-N Series. Standard target: White mat paper (Reflective type only).
 *2 The smallest detectable object was determined at the optimal detecting distance and sensitivity setting.
 *3 R10 R0.39" for the first 10 mm 0.39" of cable from the housing.

Liquid-level

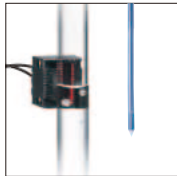

Liquid-level sensors are available in tube-mountable and immersible types.

Benefits!

Though a single beam axis was utilized in the past, this resulted in mis-detection caused by air bubbles, droplets, and other problems. The 16 beam axis is a suitable countermeasure for these types of problems.

Detecting method	Transparent tube diameter (mm)	Beam axis	Fiber unit length (Diameter)	Cable bend radius (mm)	Accessory	Model / Weight	Dimensions
Tube mountable	ø4 to 26 ø0.16" to ø1.02"	16	2 m 6.6' Free-cut (ø2.2 ø0.09" x2) -40 to +70°C (-40 to +158°F)	R5 R0.20"	Binding bandx2 Nonslip rubberx2	FU-95S	[P.48]
		1	2 m 6.6' Free-cut (ø1.0 ø0.04" x2) FU-95Z : -40 to +50°C (-40 to +122°F) FU-95HA : -40 to +105°C (-40 to +221°F)* FU-95 : -40 to +70°C (-40 to +158°F)	R2 R0.08" ToughFlex	Binding bandx2 Nonslip rubberx2 Spacerx2 Screwx2 Nutx2	FU-95Z	[P.48]
			R10 R0.39"	FU-95HA		[P.48]	
			R10 R0.39"	FU-95		[P.48]	
More than ø26 ø1.02" is recommended		16	2 m 6.6' Free-cut (ø2.2 ø0.09" x2) -40 to +70°C (-40 to +158°F)	R5 R0.20"	None (Optionally available)	FU-95W	[P.49]

Detecting method	Fiber unit length (Diameter)		Minimum bend radius (mm)		Model / Weight	Dimensions
	Ambient temperature	Appearance (mm)	PFA-sheathed section	Fiber		
Immersion	2 m 6.6' Free-cut (ø1.3 ø0.05" x2) FU-93Z: -40 to +50°C (-40 to +122°F) FU-93: -40 to +70°C (-40 to +158°F)	ø6 ø0.24" (fluorocarbon polymer)	R40* R1.57"	R0.5 R0.20" ToughFlex	FU-93Z	[P.48]
				R25 R0.98"	FU-93	[P.48]

* Not bendable up to 80 mm 3.15" from the tip.

Retro-reflective Type Transparent object detection type

Retro-reflective

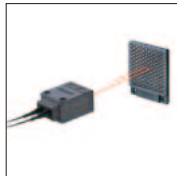

Reflectors enable stable detection with reduced installation time.

Appearance	Fiber unit length (Diameter)		Cable bend radius (mm)	Detecting distance (mm)*		Model / Weight	Dimensions
	Ambient temperature	Appearance (mm)		MEGA FINE	Other power modes		
M6	2 m 6.6' Free-cut (ø1.0 ø0.04" x2) -40 to +50°C (-40 to +122°F)	0.67" 17" M6 Reflective tape (accessory)	R2 R0.08" ToughFlex	MEGA : 10 to 960 0.39" to 37.80" FINE : 10 to 120 0.39" to 4.72"	ULTRA : 10 to 760 0.39" to 29.92" SUPER : 10 to 380 0.39" to 14.96" TURBO : 10 to 230 0.39" to 9.06" HSP : -	FU-13	[P.44]
Square type	2 m 6.6' Free-cut (ø1.0 ø0.04" x2) -20 to +55°C (-4 to +131°F) 0.82" Thickness 12.6 0.50"	1.06" 26.9" 20.8" Reflector R-2 R0.08" (accessory)	R10 R0.39"	MEGA : 100 to 6400 3.94" to 251.97" FINE : 100 to 1260 3.94" to 49.61"	ULTRA : 100 to 5000 3.94" to 196.85" SUPER : 100 to 2500 3.94" to 98.43" TURBO : 100 to 1690 3.94" to 66.54" HSP : 100 to 1000 3.94" to 39.37"	FU-15	[P.44]

* When using the FS-N Series.



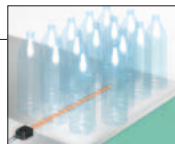

Benefits!

The optics of the FU-15 suppress the effects of refraction and deflection for stable detection of liquid-filled PET bottles and other objects. The FU-15 has an IP67 enclosure rating.



Retro-reflective/Transparent Object Detection

Reflector/Reflective Tape Specifications (Optional Parts)



Model	Power mode	R-2 (OP-95388)	R-3 (OP-96436)	R-5	Reflective tape (OP-96629)
		 51.2x61 mm 2.02" x 2.40"	 35x42 mm 1.38" x 1.65"	 14x36 mm 0.55" x 1.42"	 40x30 mm 1.57" x 1.18"
FU-13	MEGA (mm)	10 to 1880 0.39" to 74.02"	10 to 1540 0.39" to 60.63"	10 to 1060 0.39" to 41.73"	10 to 960 0.39" to 37.80"
	ULTRA (mm)	10 to 1500 0.39" to 59.06"	10 to 1240 0.39" to 48.82"	10 to 860 0.39" to 33.86"	10 to 760 0.39" to 29.92"
	SUPER (mm)	10 to 760 0.39" to 29.92"	10 to 640 0.39" to 25.20"	10 to 440 0.39" to 17.32"	10 to 380 0.39" to 14.96"
	TURBO (mm)	10 to 450 0.39" to 17.72"	10 to 360 0.39" to 14.17"	10 to 230 0.39" to 9.06"	10 to 230 0.39" to 9.06"
	FINE (mm)	10 to 250 0.39" to 9.84"	10 to 200 0.39" to 7.87"	10 to 130 0.39" to 5.12"	10 to 120 0.39" to 4.72"
FU-15*1	HSP (mm)	-	-	-	-
	MEGA (mm)	100 to 6400 3.94" to 251.97"	100 to 4400 3.94" to 173.23"	100 to 2600 3.94" to 102.36"	-
	ULTRA (mm)	100 to 5000 3.94" to 196.85"	100 to 3600 3.94" to 141.73"	100 to 2200 3.94" to 86.61"	-
	SUPER (mm)	100 to 2500 3.94" to 98.43"	100 to 2000 3.94" to 78.74"	100 to 1500 3.94" to 59.06"	-
	TURBO (mm)	100 to 1690 3.94" to 66.54"	100 to 1350 3.94" to 53.15"	100 to 1200 3.94" to 47.24"	-
	FINE (mm)	100 to 1260 3.94" to 49.61"	100 to 1000 3.94" to 39.37"	100 to 1000 3.94" to 39.37"	-
HSP (mm)	100 to 1000 3.94" to 39.37"	100 to 860 3.94" to 33.86"	100 to 860 3.94" to 33.86"	-	

*1 Reflective tape cannot be used.

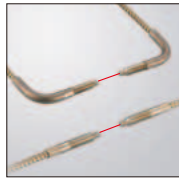
Vacuum environment type (Thrubeam)

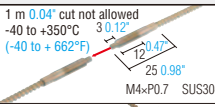

Previously requested vacuum type is added to the lineup.

Detecting method	Type	Heat resistant temperature	Fiber unit length (Diameter) Ambient temperature Appearance (mm)	Cable bend radius (mm)	Detecting distance (mm)*1		Minimum Detectable object (mm)*2	Model / Weight	Dimensions
					MEGA FINE	Other power modes			
Thrubeam type	Vacuum side	350°C 662°F	 1 m 0.04" cut not allowed -40 to +350°C (-40 to +662°F)	R25 R0.98"	MEGA : 1300 FINE : 270 10.63"	720 28.35" ULTRA : 500 SUPER : 19.69" TURBO : 360 HSP : 14.17" 135 5.32"	ø0.005 ø0.0002" Opaque	FU-V84 NEW Approx. 55 g	[P.50]
		350°C 662°F	 1 m 0.04" cut not allowed -40 to +350°C (-40 to +662°F)					FU-V84L NEW Approx. 60 g	[P.50]
	Atmosphere side	70°C 158°F	 2 m 0.08" Free-cut (ø2.2 ø0.09") -40 to +70°C (-40 to +158°F) Across-flats: 8 0.32" 10 0.39"					FU-V7FN NEW Approx. 30 g	[P.50]

*1 Common for APC ON/OFF when the FS-N Series is used.

*2 The smallest detectable object was determined at the optimal detecting distance and sensitivity setting.

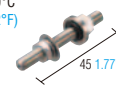
Detecting method	Heat resistant temperature	Ambient temperature Appearance (mm)	Material	Accessory	Model / Weight	Dimensions
Optical integrator thrubeam 1 set connection type	200°C 392°F	-10 to +200°C (14 to +392°F) 	Unit housing: SUS304 Fiber: Multicomponent glass	·M5 nut, spring washer, washer: 2 each: SUS304 ·2 O-rings: Fluoro-rubber	FU-VJ1 NEW Approx. 25 g	[P.50]

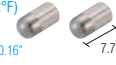
Detecting method	Heat resistant temperature	Ambient temperature Appearance (mm)	Applicable fiber units	Detecting distance (mm)*3						Model / Weight	Dimensions
				MEGA	ULTRA	SUPER	TURBO	FINE	HSP		
For vacuum long-distance Lens	350°C 662°F	-10 to +350°C (14 to +662°F)  Tip: ø4 ø0.16" 7.7 0.3"	FU-V84 FU-V84L	5600 220.47"	4000 157.48"	2600 102.36"	1800 70.87"	1200 47.24"	600 23.62"	F-V2 NEW Approx. 2 g	[P.50]

*3 Common for APC ON/OFF when the FS-N Series is used.

Detecting method	Heat resistant temperature	Ambient temperature Appearance (mm)	Features	Material/Accessory	Model / Weight	Dimensions
2 channel chamber flange	200°C 392°F	-10 to +200°C (14 to +392°F)  ø70 ø2.76"	·2 sets of optical integrators are connectable. External diameter ø70 ø2.76" and O-ring ø40 ø1.57". Refer to the dimensions for the appearance.	[Material] SUS304 [Accessory] 1xO-ring Material: Fluoro-rubber	FU-VJ2 NEW Approx. 280 g	[P.50]

How to mount the optical integrator

The optical integrator seals and isolates the vacuum and atmosphere sides while still transmitting light from the vacuum fiber to the atmosphere fiber. All optical integrators have been leak tested. (Leak amount: 1x10⁻¹⁰Pa·m³/sec max, at helium leak test)

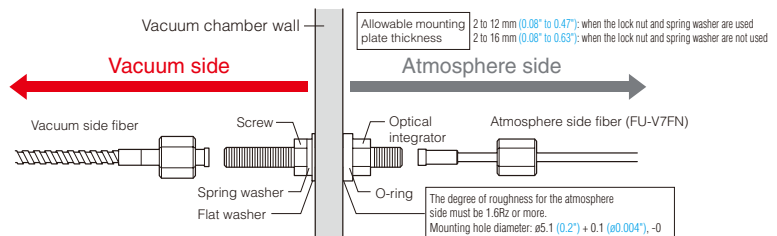

Amplifier

Cable type

Type	Appearance	Model		Control outputs	External input	Monitor output	Dimensions
		NPN output	PNP output				
Standard	Main unit		FS-N11N	FS-N11P	1	0	[P.52]
	Expansion unit		FS-N12N	FS-N12P			
2 output	Main unit		FS-N13N	FS-N13P	2	1	
	Expansion unit		FS-N14N	FS-N14P			
Monitor output	Main unit	FS-N11MN	–	1	0	1	

M8 connector type

Type	Appearance	Model		Control outputs	External input	Monitor output	Dimensions
		NPN output	PNP output				
Standard	Main unit		FS-N11CN	FS-N11CP	1	1	[P.52]
	Expansion unit		FS-N12CN	FS-N12CP			
2 output	Main unit		–	FS-N13CP	2	0	
	Expansion unit		–	FS-N14CP			

Zero line type

Type	Appearance	Model	Control outputs	External input	Monitor output	Dimensions
Expansion unit (No output line)		FS-N10	None*1	0	0	[P.53]

*1 Counted as one output when added to a NU Series communication unit.

Specifications

Type		Standard 1 output				High functionality 2 output				Monitor output	Zero line
Cable/M8 connector		Cable		M8 connector *1		Cable		M8 connector *1		Cable	–
Main/Expansion unit		Main unit	Expansion unit	Main unit	Expansion unit	Main unit	Expansion unit	Main unit	Expansion unit	Main unit	Expansion unit (No output wire)
Model	NPN	FS-N11N	FS-N12N	FS-N11CN	FS-N12CN	FS-N13N	FS-N14N	–	–	FS-N11MN	FS-N10
	PNP	FS-N11P	FS-N12P	FS-N11CP	FS-N12CP	FS-N13P	FS-N14P	FS-N13CP	FS-N14CP	–	
IO	Control outputs	1 output	1 output	1 output	1 output	2 output	2 output	2 output	2 output	1 output	None*2
	Monitor output (1 to 5 V)	–	–	–	–	–	–	–	–	1 output	–
	External input	–	–	1 input	1 input	1 input	1 input	–	–	–	–
Light source LED		Red, 4-element LED (Wavelength: 630 nm)									
Response time		50 μs (HIGH SPEED)/250 μs (FINE)/500 μs (TURBO)/1 ms (SUPER)/4 ms (ULTRA)/16 ms (MEGA)									
Output selection		LIGHT-ON/DARK-ON (switch-selectable)									
Timer function		Timer OFF/OFF-delay timer/ON-delay timer/One-shot timer									
Control outputs	NPN output	NPN open collector 24 V, (without expansion) for one output: 100 mA max., two output total: 100 mA max., (with expansion) 20 mA max for one output, residual voltage 1 V max.									
	PNP output	PNP open collector 24 V, (without expansion) for one output: 100 mA max., two output total: 100 mA max., (with expansion) 20 mA max for one output, residual voltage 1 V max.									
Monitor output*3		1 to 5 V voltage output; load resistance 10 kΩ or more; repeat precision ±0.5% of F.S.; response time: 1 ms (HIGH SPEED, FINE, TURBO)*4									
External input		Input time 2 ms (ON)/20 ms (OFF) or more*5									
Multiple connections to expansion units		Up to 16 units can be connected in total (two-output type is treated as two units)									
Protection circuit		Reverse polarity protection, Over-current protection, Surge absorber									
Number of interference prevention units		0 for HIGH SPEED; 4 for FINE; 8 for TURBO/SUPER/ULTRA/MEGA (When set to DOUBLE, the number of interference-prevention units will be doubled.)									
Rating	Power voltage	12 to 24 VDC ±10% ripple (P-P) 10% or less									
	NPN	Normal: 900 mW or less (36 mA max. at 24 V, 48 mA max. at 12 V)*6 Eco on mode: 800 mW or less (32 mA max. at 24 V, 39 mA max. at 12 V)*6 Eco Full mode: 470 mW or less (19 mA max. at 24 V, 23 mA max. at 12 V)									
	PNP	Normal: 1050 mW or less (42 mA max. at 24 V, 56 mA max. at 12 V)*6 Eco on mode (ALL): 950 mW or less (38 mA max. at 24 V, 47 mA max. at 12 V)*6 Eco Full mode: 600 mW or less (24 mA max. at 24 V, 29 mA max. at 12 V)									
Environmental resistance	Ambient light	Incandescent lamp: 20,000 lux max., Sunlight: 30,000 lux max.									
	Ambient temperature	-20°C to +55°C (-4 to +131°F) (No freezing)*7									
	Relative humidity	35 to 85% RH (No condensation)									
	Vibration resistance	10 to 55 Hz, double amplitude 1.5 mm 0.06", 2 hours for each of X,Y,Z axis									
	Shock resistance	500 m/s ² 3 times for each of X,Y and Z axis									
Case material		Main unit and cover material: Polycarbonate									
Case size		H 30.3 mm 1.19" × W 9.8 mm 0.39" × L 71.8 mm 2.83"									
Weight		Approx. 75 g	Approx. 45 g	Approx. 22 g	Approx. 22 g	Approx. 80 g	Approx. 70 g	Approx. 22 g	Approx. 22 g	Approx. 75 g	Approx. 20 g

*1 Use a cable length of 30 m 98.43' or less for M8 connector type. *2 Counted as one output when added to a NU Series communication unit.

*3 FS-N11MN only. *4 SUPER : 1.2 ms, ULTRA : 1.8 ms, MEGA : 4.2 ms. *5 Input time is 25 ms (ON)/25 ms (OFF) when external calibration time is selected.

*6 Increases 100 mW (4.0 mA) for HIGH SPEED mode.

*7 One or two more units connected: -20 to +55°C (-4 to +131°F); 3 to 10 more units connected: -20 to +50°C (-4 to +122°F); 11 to 16 more units connected: -20 to +45°C (-4 to +113°F).

When using 2-outputs, one unit is counted as two units. All temperature regulations are for when the unit is mounted on a DIN rail and installed on metal sheeting.

I/O Circuit Diagram

Cable type

FS-N11N / N12N / N13N / N14N

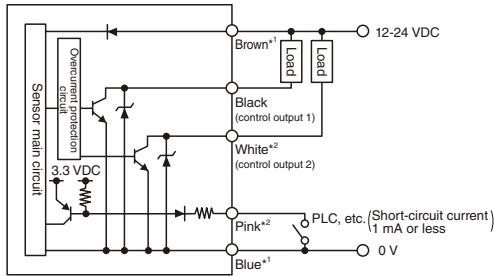

*1 FS-N11N / N13N only
*2 FS-N13N / N14N only

FS-N11P / N12P / N13P / N14P

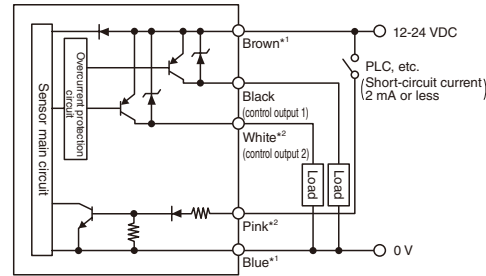

*1 FS-N11P / N13P only
*2 FS-N13P / N14P only

Monitor output type

FS-N11MN

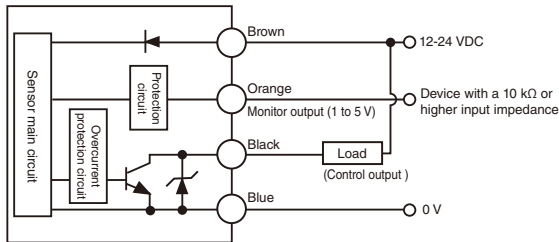

M8 connector type

FS-N11CN / N12CN

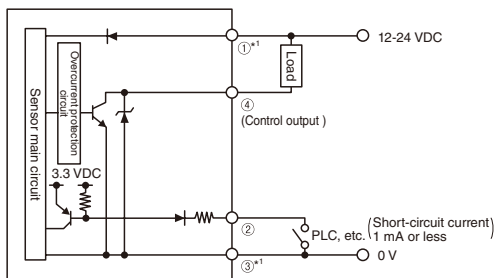

*1 FS-N11CN only

M8 connector pin layout



FS-N11CP / N12CP / N13CP / N14CP

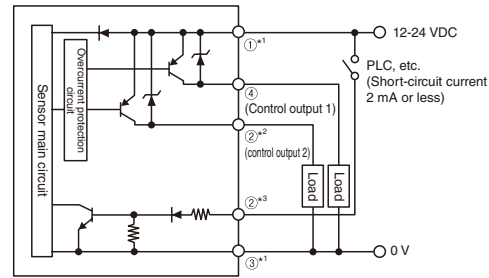

*1 FS-N11CP/N13CP only
*2 FS-N13CP/N14CP only
*3 FS-N11CP/N12CP only

M8 connector pin layout



M8 Connector Cable (sold separately)

FS-N11Cx / N12Cx / N13CP / N14CP

OP-73864 (Cable length: 2 m 6.6')
OP-73865 (Cable length: 10 m 32.8')

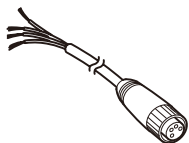

Pin - wire color

Connected pin number	Core wire cover color
①	Brown
②	White
③	Blue
④	Black

M8 connector junction cable (sold separately)

OP-85498

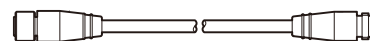

Sensor head Dimensions

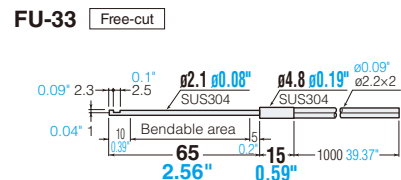
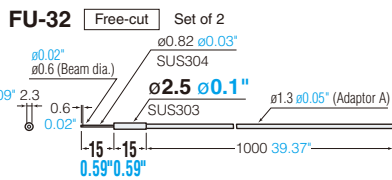
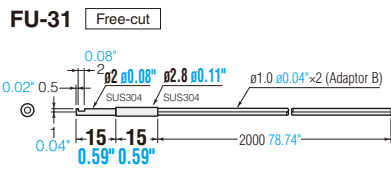
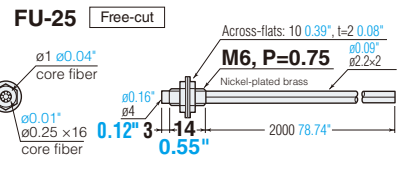
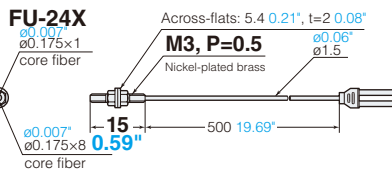
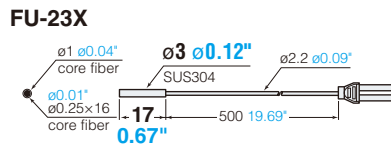
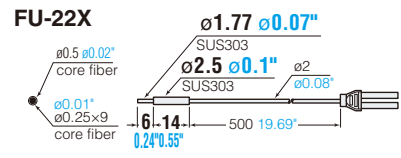
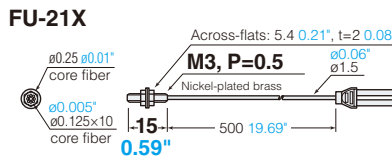
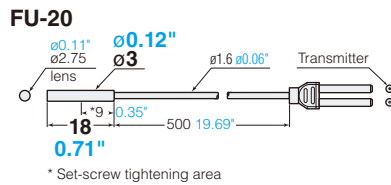
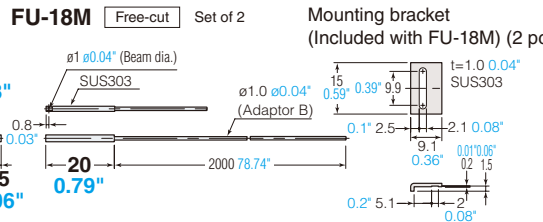
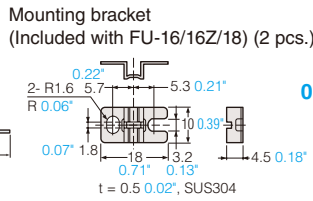
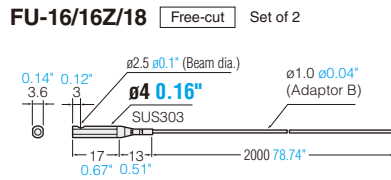
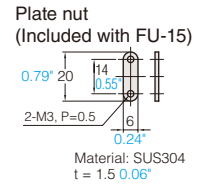
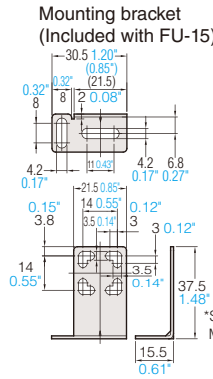
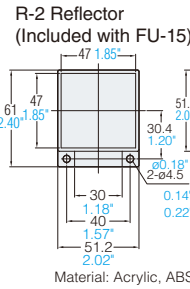
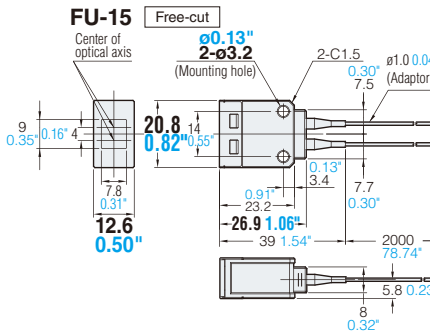
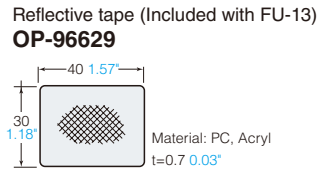
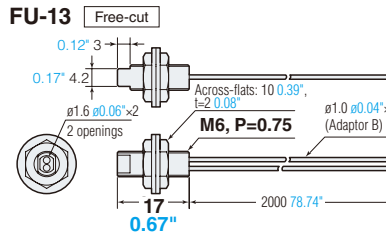
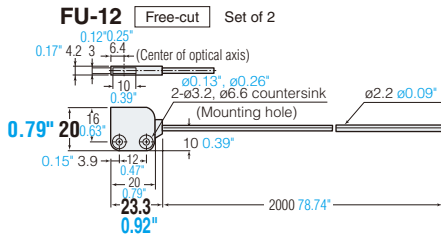
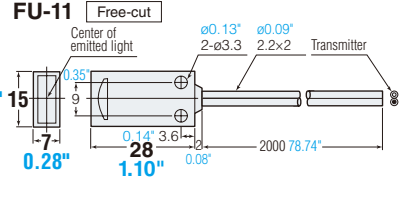
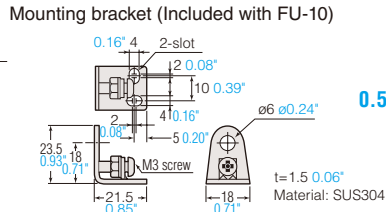
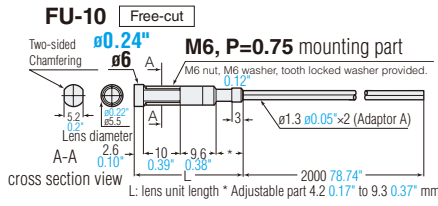

Sensor head Dimensions

FU-43 Free-cut

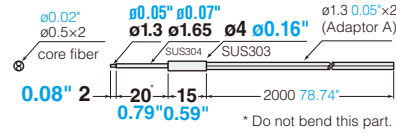

FU-44TZ Free-cut

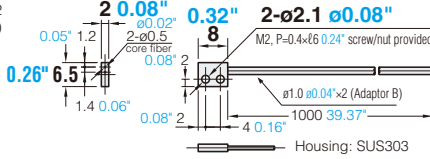

FU-45X

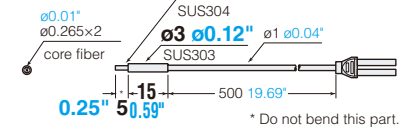

FU-46

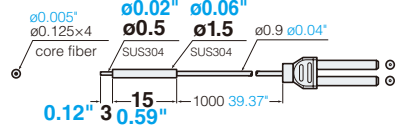

FU-47TZ Free-cut

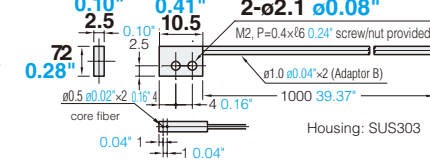

FU-48 Free-cut

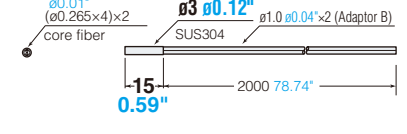

FU-48U Free-cut

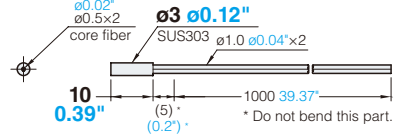

FU-49U Free-cut

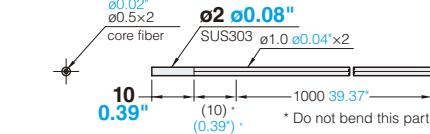

FU-49X

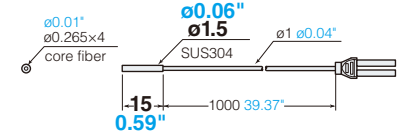

FU-5F/5FZ Free-cut Set of 2

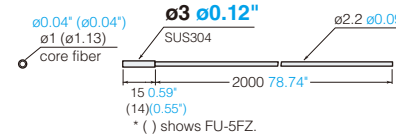

FU-50 Free-cut Set of 2

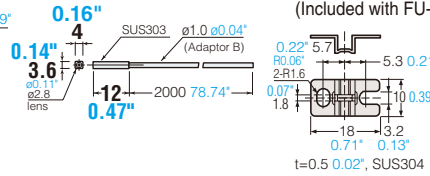

FU-51TZ Free-cut Set of 2

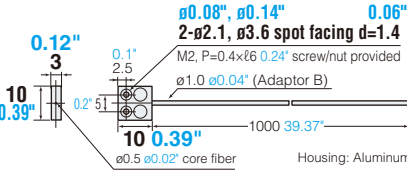

FU-52TZ Free-cut Set of 2

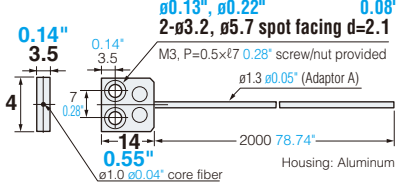

FU-53TZ Free-cut Set of 2

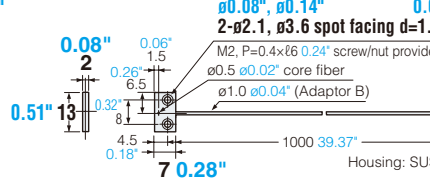

FU-54TZ Free-cut Set of 2

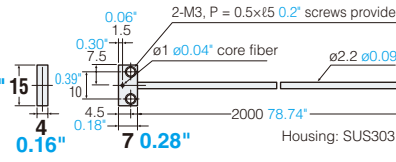

FU-55

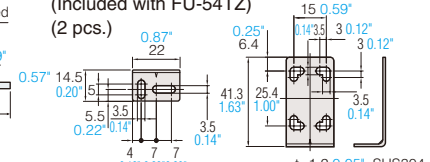

FU-55

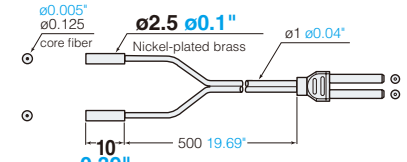

FU-56

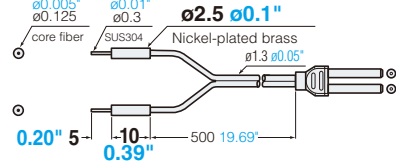

FU-57TE/57TZ Free-cut Set of 2

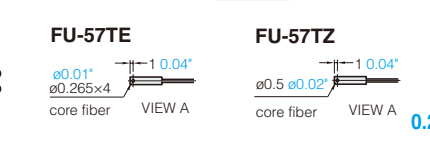

FU-57TE

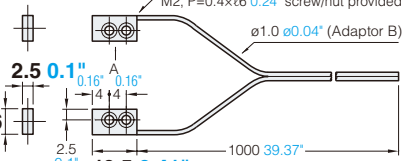

FU-58

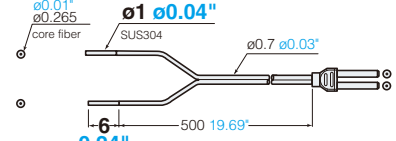

FU-58U Free-cut Set of 2

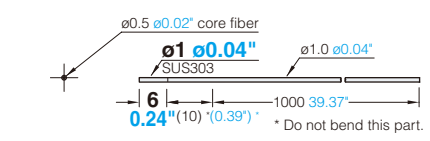

FU-59 Free-cut Set of 2

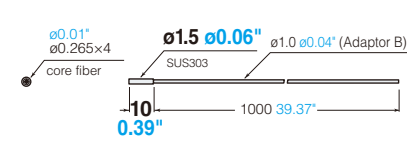

FU-59U Free-cut Set of 2

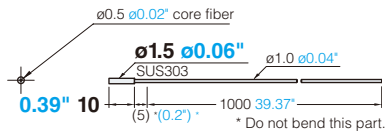

FU-6F Free-cut

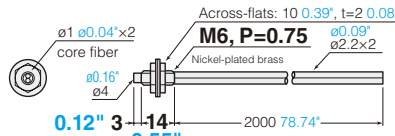

FU-61/61Z Free-cut

Unit : mm inch

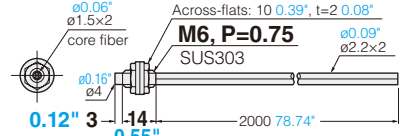

FU-63 Free-cut

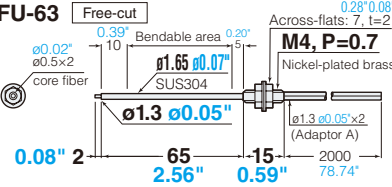

FU-63T Free-cut

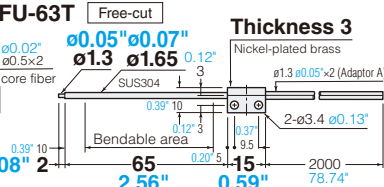

FU-63Z Free-cut

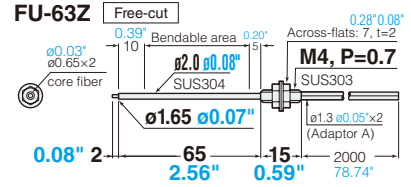

FU-65X

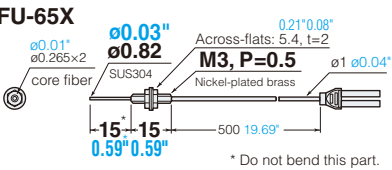

FU-66/66Z Free-cut

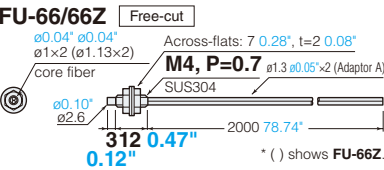

FU-66TZ Free-cut

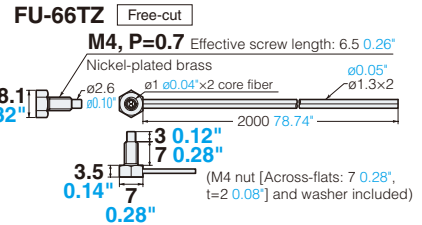

FU-67/67V Free-cut

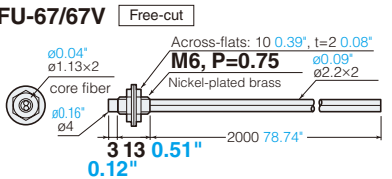

FU-67G

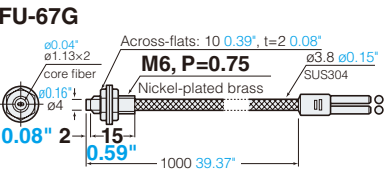

FU-67TG

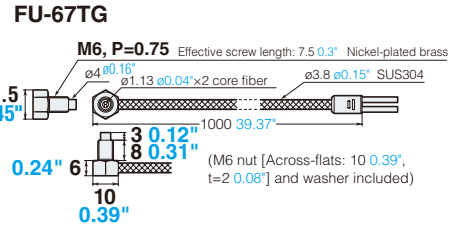

FU-67TZ Free-cut

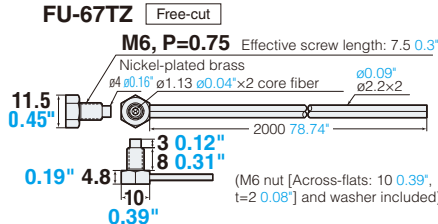

FU-68 Free-cut

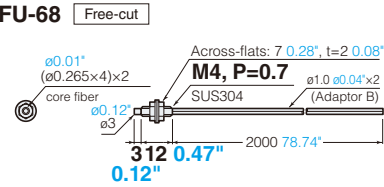

FU-69U Free-cut

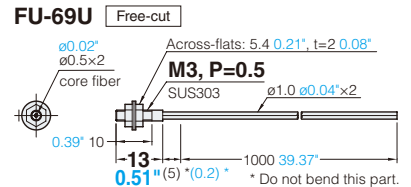

FU-69X

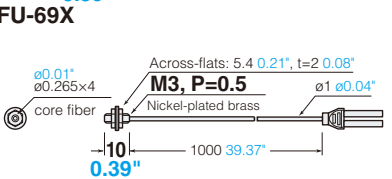

FU-7F Free-cut Set of 2

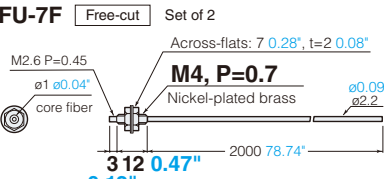

FU-70U Free-cut Set of 2

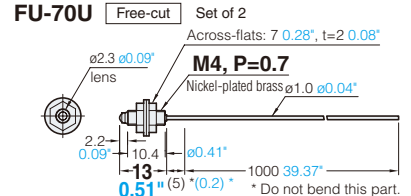

FU-71/71Z Free-cut Set of 2

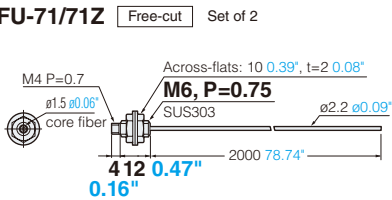

FU-73 Free-cut Set of 2

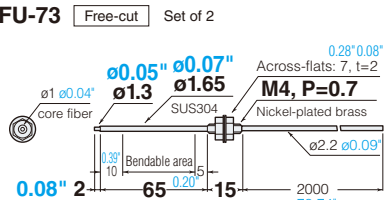

FU-75F Free-cut Set of 2

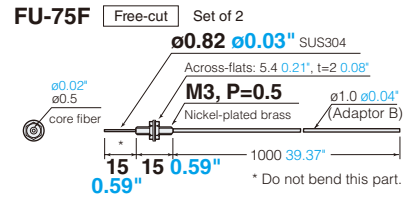

FU-76F Free-cut Set of 2

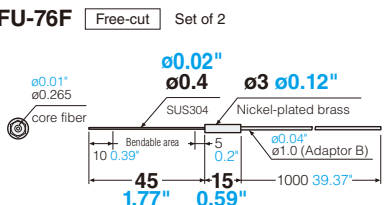

FU-77/77V Free-cut Set of 2

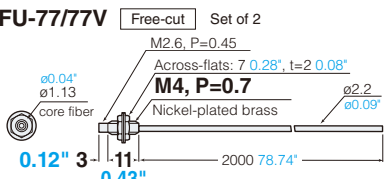

FU-77G

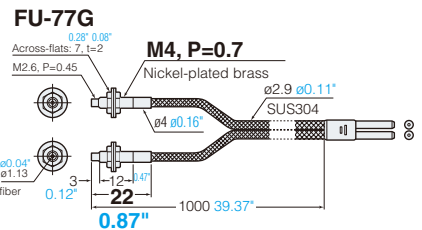

neoPRESET

LV-neo

Specifications Dimensions

FS-neo&FU

Specifications Dimensions

PS-neo

Specifications Dimensions

NU series

Sensor head Dimensions

FU-77TG Set of 2

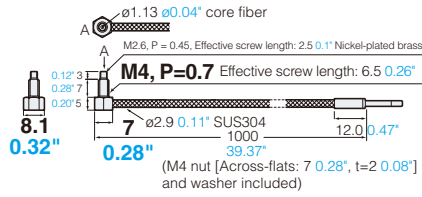

FU-77TZ Free-cut Set of 2

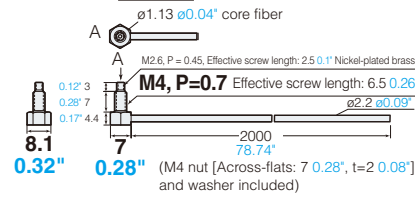

FU-78 Free-cut Set of 2

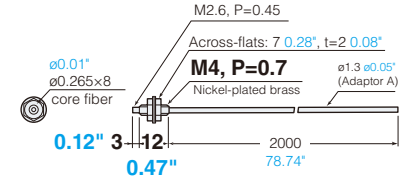

FU-79 Free-cut Set of 2

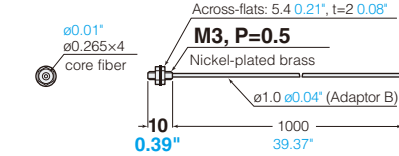

FU-79U Set of 2

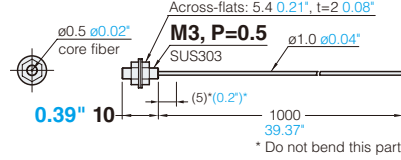

FU-81C

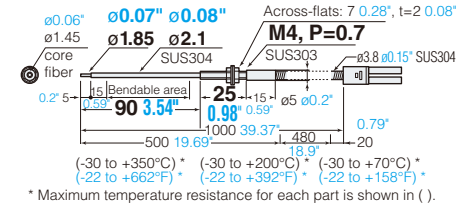

FU-82C

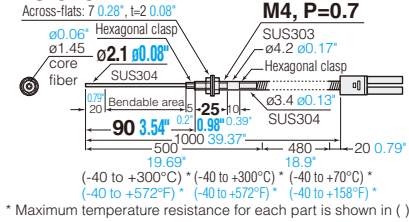

FU-83C

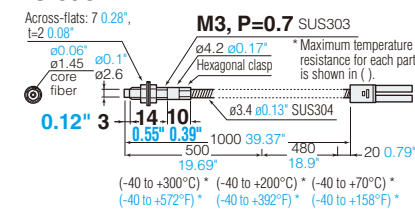

FU-84C

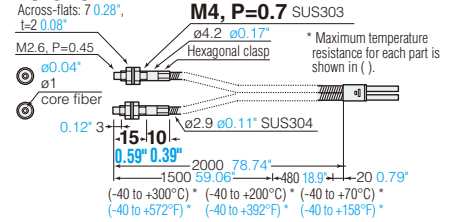

FU-85A Free-cut

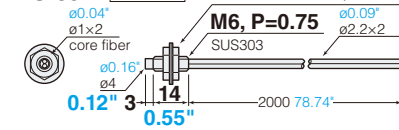

FU-85H Free-cut

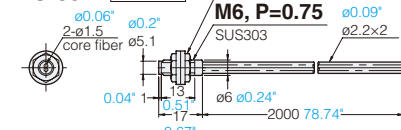

FU-85Z Free-cut

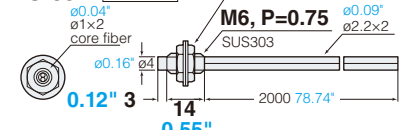

FU-86A Free-cut Set of 2

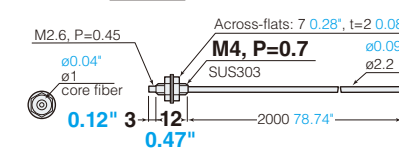

FU-86H Free-cut Set of 2

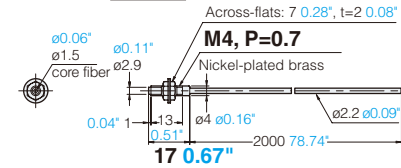

FU-86Z Free-cut Set of 2

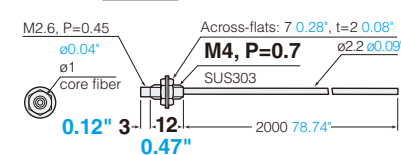

FU-87 Free-cut

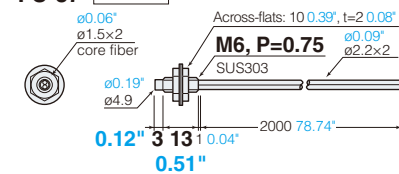

FU-87K

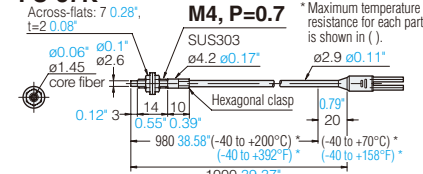

FU-88 Free-cut Set of 2

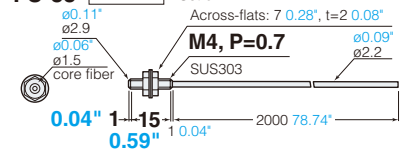

FU-88K

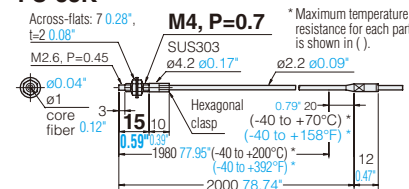

FU-91 Free-cut

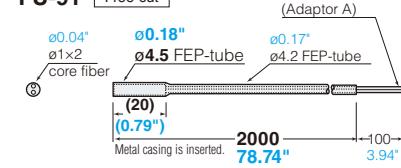

FU-92 Free-cut Set of 2

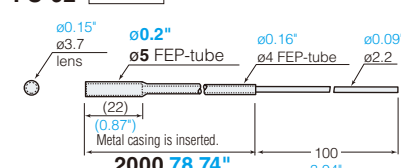

FU-93/93Z Free-cut

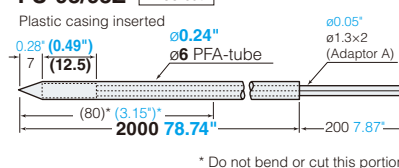

FU-95/95HA/95Z Free-cut

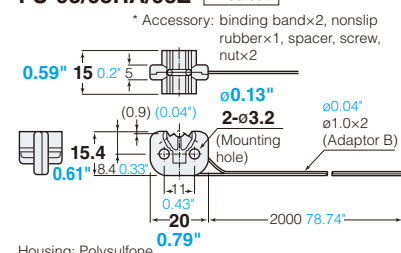

FU-95S Free-cut

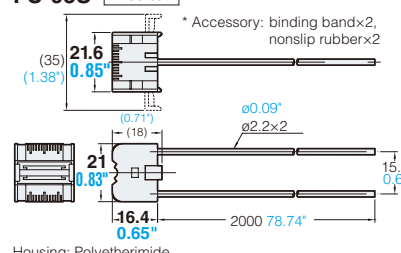

Sensor Head/Lens Dimensions

FU-L41Z Free-cut

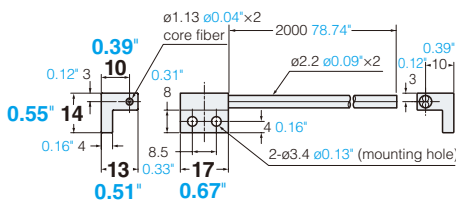

FU-L50Z Free-cut Set of 2

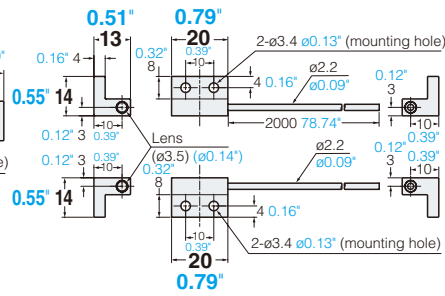

FU-L51Z/L52Z/L53Z Free-cut Set of 2

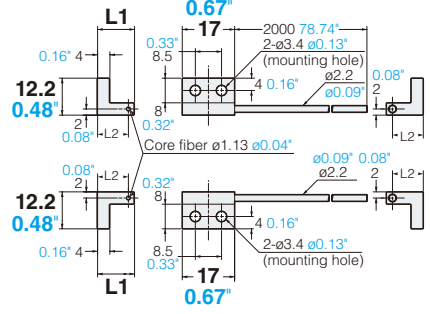

Model	L1	L2
FU-L51Z	12.2 0.48"	10 0.39"
FU-L52Z	17 0.67"	15 0.59"
FU-L53Z	22 0.87"	20 0.79"

FU-L54Z Free-cut Set of 2

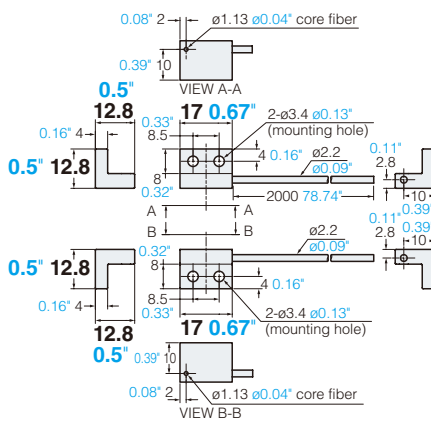

FU-V7FN

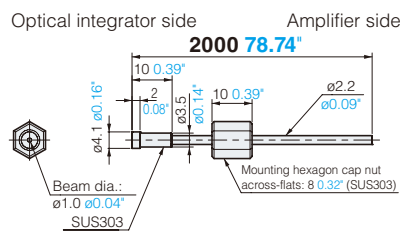

FU-V84

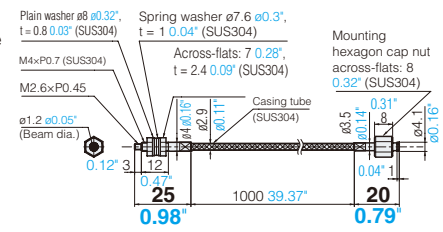

FU-V84L

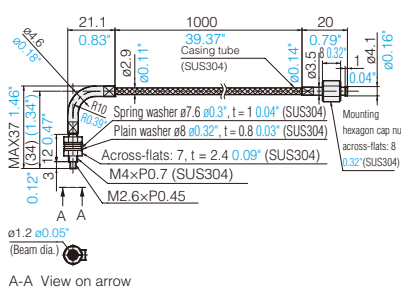

FU-VJ1

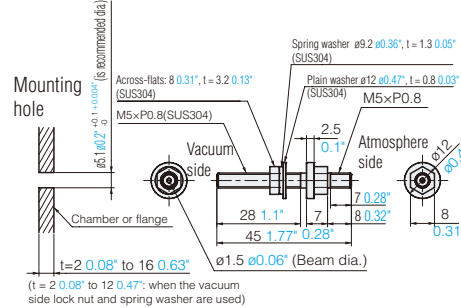

FU-VJ2

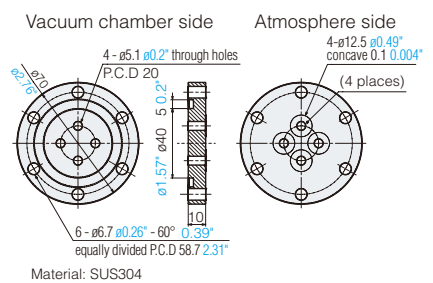

F-1 2 per set

Housing: Nickel-plated brass
Lens: Acrylic

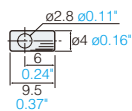

F-2 2 per set

Housing: Nickel-plated brass
Lens: Glass



F-4 2 per set

Housing: Aluminum
Lens: Glass

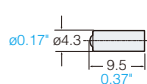

F-5 2 per set

Housing: Aluminum
Lens: Glass

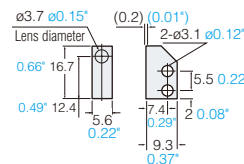

F-2HA

Housing: Aluminum
Lens: Plastic

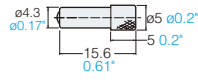

F-3HA

Housing: Aluminum
Lens: Plastic

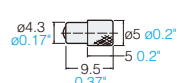

F-4HA

Housing: Aluminum
Lens: Glass

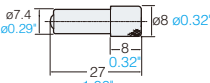

F-5HA

Housing: Aluminum
Lens: Glass

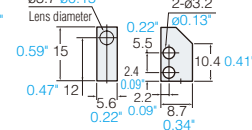

F-6HA

Housing: Aluminum
Lens: Plastic

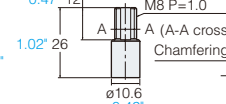

F-V2 2 per set

Housing: SUS304
Lens: BK-7



With lenses

**F-1+
FU-7F/86A/86Z**

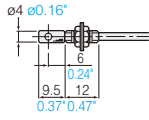

**F-1+
FU-77/77V**

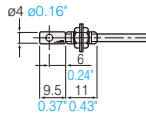

**F-1+
FU-77G**

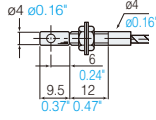

**F-1+
FU-84C/88K**

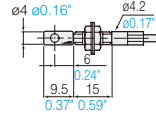

**F-2+
FU-7F/86A/86Z**

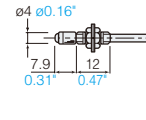

**F-2+
FU-77/77V**

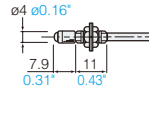

**F-2+
FU-77G**

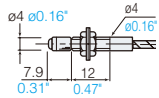

**F-2+
FU-77TG**

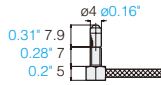

**F-2+
FU-84C/88K**

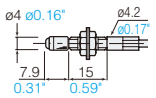

**F-4+
FU-7F**

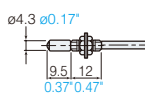

**F-4+
FU-77/77V**

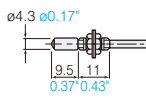

**F-4+
FU-77G**

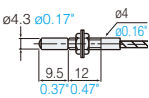

**F-4+
FU-77TG**

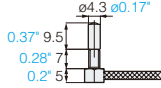

**F-5+
FU-7F/86A/86Z**

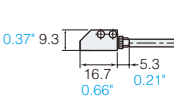

**F-5+
FU-77/77V**

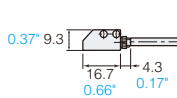

**F-5+
FU-77G**

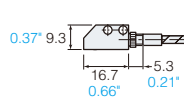

**F-2HA+
FU-21X/FU-24X**

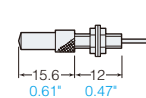

**F-2HA+
FU-35FA**

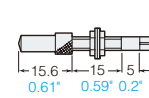

**F-2HA+
FU-35FG**

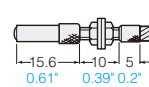

**F-2HA+
FU-35FZ**

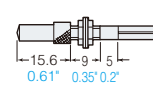

**F-2HA+
FU-35TG**

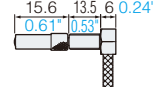

**F-2HA+
FU-35TZ**

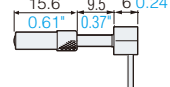

**F-3HA+
FU-35FA**

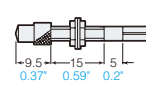

**F-3HA+
FU-35FG**

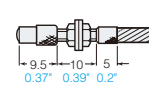

**F-3HA+
FU-35FZ**

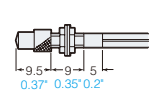

**F-3HA+
FU-35TG**

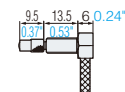

**F-3HA+
FU-35TZ**

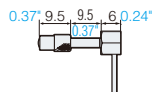

**F-4HA+
FU-35FA**

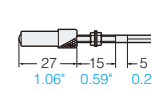

**F-4HA+
FU-35FG**

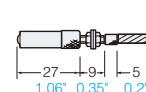

**F-4HA+
FU-35FZ**

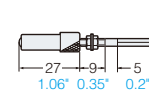

**F-4HA+
FU-35TG**

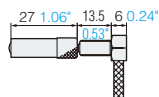

**F-4HA+
FU-35TZ**

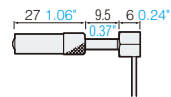

**F-5HA+
FU-35FA**

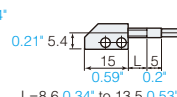

**F-5HA+
FU-35FG**

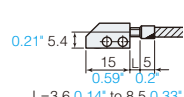

**F-5HA+
FU-35FZ**

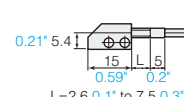

**F-6HA+
FU-21X**

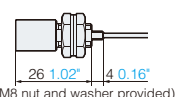

**F-6HA+
FU-35FA**

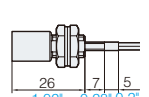

**F-6HA+
FU-35FG**

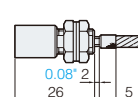

**F-6HA+
FU-35FZ**

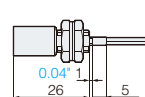

**F-6HA+
FU-35TZ**

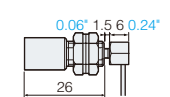

**F-V2+
FU-V84**

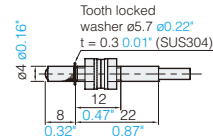

**F-V2+
FU-V84L**

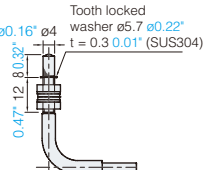

(M8 nut and washer provided)

(M8 nut and washer provided)

(M8 nut and washer provided)

(M8 nut and washer provided)

FS-N11N / N11P / N13N / N13P / N11MN

Cable type, Main unit

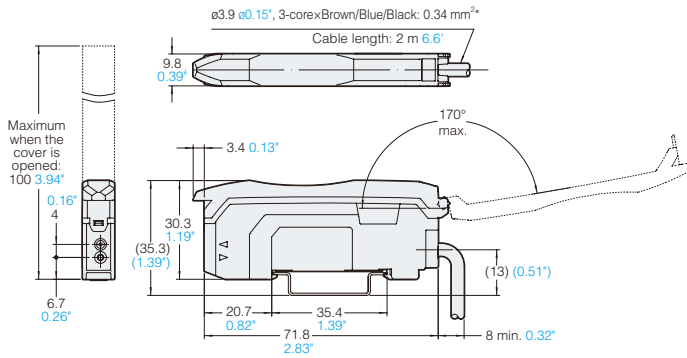

*FS-N11MN: $\phi 3.9$ $\phi 0.15$, 4-core \times Brown/Blue: 0.34 mm², Black/Orange 0.18 mm²
 FS-N13N/N13P: $\phi 3.9$ $\phi 0.15$, 5-core \times Brown/Blue: 0.34 mm², Black/White/Pink 0.18 mm²

FS-N12N / N12P / N14N / N14P

Cable type, Expansion unit

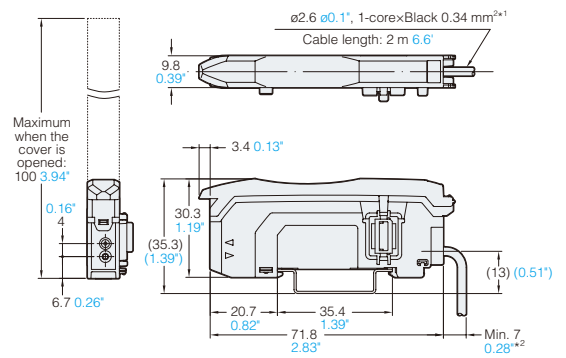

*1 FS-N14N/N14P: $\phi 3.9$ $\phi 0.15$, 3-core \times Black/White/Pink: 0.18 mm²
 *2 FS-N14N/N14P: min. 8 0.32"

FS-N11CN / N11CP / N13CP

M8 connector type, Main unit

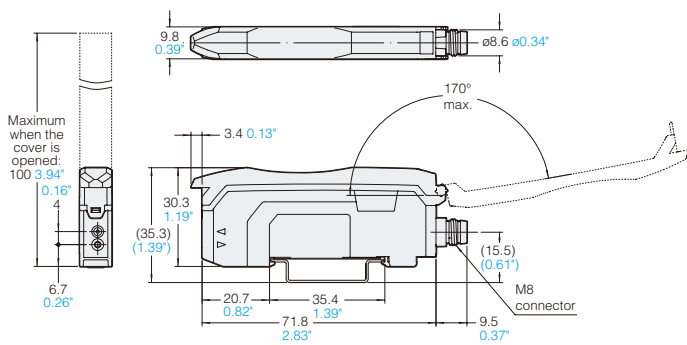

FS-N12CN / N12CP / N14CP

M8 connector type, Expansion unit

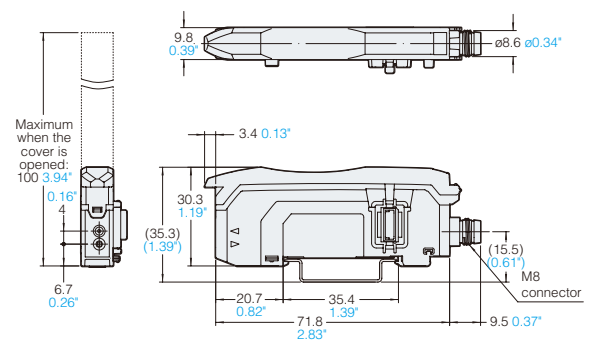

M8 connector cable (**OP-73864/73865** sold separately)

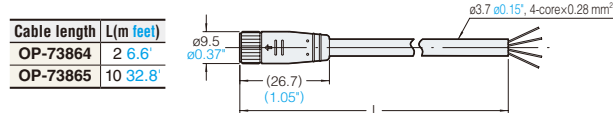

M8 connector junction cable (**OP-85498** sold separately)

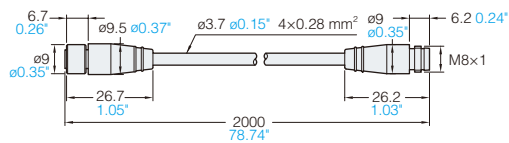

FS-N10

Zero line type, Expansion unit

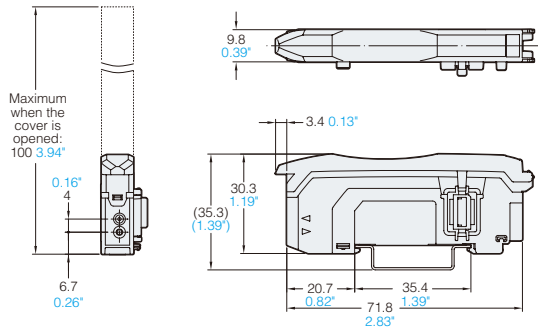

OP-87199

Conversion adaptor

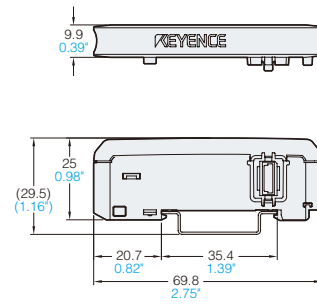

When the mounting bracket is attached (**OP-73880** sold separately)

Cable type

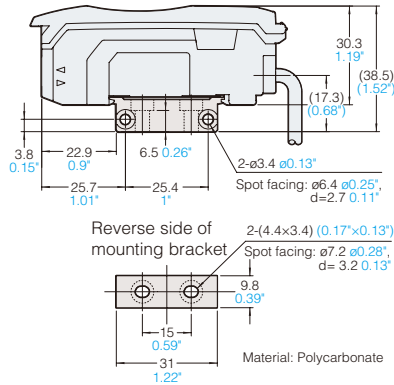

M8 connector type

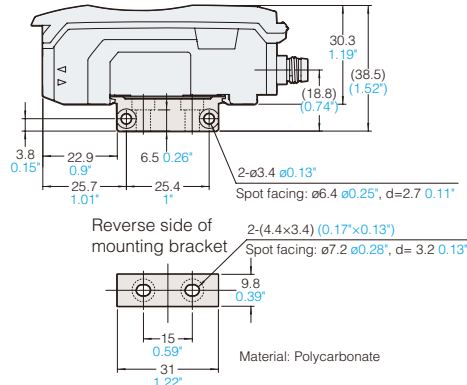

Common for all types

When several units are connected:

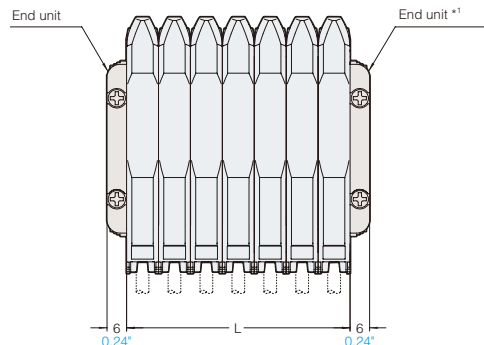

No. of units	L (mm inch)
1	9.8 0.39"
2	19.6 0.77"
3	29.4 1.16"
4	39.2 1.54"
5	49.0 1.93"
6	58.8 2.32"
7	68.6 2.7"
8	78.4 3.09"
9	88.2 3.47"
10	98.0 3.86"
11	107.8 4.24"
12	117.6 4.63"
13	127.4 5.02"
14	137.2 5.4"
15	147.0 5.79"
16	156.8 6.17"
17	166.6 6.56"

*1 End units must be used when several units are connected. (OP-26751)

End unit

(**OP-26751** sold separately)

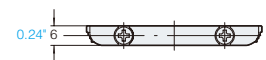

DIN-rail mounting

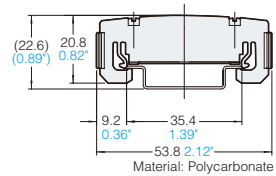

High environmental resistance & cable extension capabilities provide increased installation versatility



Extendable sensor head cable

Because the sensor head cable is a simple power cable, it can be extended to the desired length. By soldering or using a metal connector, it can be extended to a maximum of 10 m (32.81').

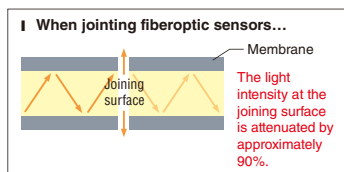

Small size yet high power

While the conventional PS Series had only "FINE" and "TURBO" modes, it is now equipped with additional power modes including "MEGA" mode, like the FS-N Series. This allows the PS Series to be used in applications where strong light intensity is required.



Wide range of sensor head options

The PS Series lineup includes a broad range of sensor heads that have a wide variety of special characteristics, such as the environmentally resistant models that are encased in PFA for protection, or the limited range reflective models that are able to avoid the effects of background light.

PS-NEO FUNCTION

- NEO Preset
- NEO MEGA
- Built-in application modes
- DATUM function
- Open field network compatibility
- Reduced wiring
- Interference prevention function
- Pause function
- Sleep function

Thrubeam type

Type	Appearance	Detecting distance (mm inch) ^{*1}	Features	Model (C means with connector)	Dimensions
Thrubeam type		MEGA : 3600 (6000) 141.73" (236.22") ULTRA : 2800 (5000) 110.24" (196.85") SUPER : 2200 (4200) 86.61" (165.35") TURBO : 2000 (4000) 78.74" (157.48")	Compact body and long-detecting distance	PS-55 (PS-55C)	[P.59]
		MEGA : 3600 (6000) 141.73" (236.22") ULTRA : 2800 (5000) 110.24" (196.85") SUPER : 2200 (4200) 86.61" (165.35") TURBO : 2000 (4000) 78.74" (157.48")	Compact body and long-detecting distance easy optical-axis alignment	PS-05	[P.58]
		MEGA : 1000 39.37" ULTRA : 900 35.43" SUPER : 750 29.53" TURBO : 700 27.56"	Cylindrical, embedded type	PS-58	[P.59]
		MEGA : 1200 (1500) 47.24" (59.06") ULTRA : 800 (1000) 31.50" (39.37") SUPER : 400 (650) 15.75" (25.59") TURBO : 300 (600) 11.81" (23.62")	Side-to-side type, 3 mm 0.12" thickness	PS-52 (PS-52C)	[P.59]
		MEGA : 750 (900) 29.53" (35.43") ULTRA : 500 (600) 19.69" (23.62") SUPER : 400 (450) 15.75" (17.72") TURBO : 300 (400) 11.81" (15.75")	Flat-to-flat type 2.8 mm 0.11" thickness	PS-56	[P.59]
	Environment-proof		MEGA : 3600 (6000) 141.73" (236.22") ULTRA : 2800 (5000) 110.24" (196.85") SUPER : 2200 (4200) 86.61" (165.35") TURBO : 2000 (4000) 78.74" (157.48")	PFA-sheath type, oil-proof, chemical proof	PS-201 (PS-201C)
		MEGA : 900 (1000) 35.43" (39.37") ULTRA : 700 (900) 27.56" (35.43") SUPER : 600 (800) 23.62" (31.50") TURBO : 500 (750) 19.69" (29.53")	PFA-sheath type, Slit ^{*2} built-in	PS-202	[P.59]

^{*1} Depends on the mode, response time may be different even with the same detecting distance. Detecting distance in parentheses is a value when enabling the long distance detection mode with a 5 m sensor head cable.

^{*2} 5x1 mm 0.2"x0.04" slits for both transmitter/receiver.

Reflective model

Type	Appearance	Detecting distance (mm inch) ^{*1}	Features	Model (C means with connector)	Dimensions
Diffuse-reflective		MEGA : 600 (900) 23.62" (35.43") ULTRA : 400 (600) 15.75" (23.62") SUPER : 250 (450) 9.84" (17.72") TURBO : 200 (400) 7.87" (15.75")	Compact body and long-detecting distance	PS-45	[P.58]
		MEGA : 200 (250) 7.87" (9.84") ULTRA : 150 (200) 5.91" (7.87") SUPER : 120 (160) 4.72" (6.30") TURBO : 100 (140) 3.94" (5.51")	Flat-to-flat type 2.8 mm 0.11" thickness	PS-46	[P.58]
		MEGA : 75 2.95" ULTRA : 45 1.77" SUPER : 30 1.18" TURBO : 25 0.98"	Cylindrical, embedded type	PS-48	[P.58]
Environment-proof		MEGA : 600 (900) 23.62" (35.43") ULTRA : 400 (600) 15.75" (23.62") SUPER : 250 (450) 9.84" (17.72") TURBO : 200 (400) 7.87" (15.75")	PFA-sheath type, oil-proof, chemical proof	PS-205	[P.59]
		MEGA : 250 9.84" ULTRA : 180 7.09" SUPER : 100 3.94" TURBO : 70 2.76"	PFA-sheath type, Focused beam small spot	PS-206	[P.59]
Definite-reflective		10 0.39"±4 0.16" * Common for all power modes	Small Spot ø0.8 mm ø0.03" almost unaffected by target background	PS-47 (PS-47C)	[P.58]
		32 1.26" to 53 2.09" * Common for all power modes	Long distance small spot almost unaffected by target background	PS-49 (PS-49C)	[P.58]

^{*1} Depends on the mode, response time may be different even with the same detecting distance. Detecting distance in parentheses is a value when enabling the long distance detection mode.

Sensor head specifications

Thrubeam sensor head

Type		Thrubeam type						
		General purpose					Environment-proof	
		Long-detecting distance	Free-positioning	Cylindrical	Thin		Long-detecting distance	Slit built-in
Model	PS-55 (C)	PS-05	PS-58	PS-52 (C)	PS-56	PS-201 (C)	PS-202	
Detecting distance*1 (mm inch)	MEGA	3600 (6000) 141.73" (236.22")	3600 (6000) 141.73" (236.22")	1000 39.37"	1200 (1500) 47.24" (59.06")	750 (900) 29.53" (35.43")	3600 (6000) 141.73" (236.22")	900 (1000) 35.43" (39.37")
	ULTRA	2800 (5000) 110.24" (196.85")	2800 (5000) 110.24" (196.85")	900 35.45"	800 (1000) 31.50" (39.37")	500 (600) 19.69" (23.62")	2800 (5000) 110.24" (196.85")	700 (900) 27.56" (35.43")
	SUPER	2200 (4200) 86.61" (165.35")	2200 (4200) 86.61" (165.35")	750 29.53"	400 (650) 15.75" (25.59")	400 (450) 15.75" (17.72")	2200 (4200) 86.61" (165.35")	600 (800) 23.62" (31.50")
	TURBO	2000 (4000) 78.74" (157.48")	2000 (4000) 78.74" (157.48")	700 27.56"	300 (600) 11.81" (23.62")	300 (400) 11.81" (15.75")	2000 (4000) 78.74" (157.48")	500 (750) 19.69" (29.53")
Light source		Infrared LED						
Smallest detectable object*2		ø1.0 mm ø0.04" Opaque	ø1.0 mm ø0.04" Opaque	ø0.5 mm ø0.02" Opaque	ø0.3 mm ø0.01" Opaque	ø0.3 mm ø0.01" Opaque	ø0.8 mm ø0.03" Opaque	ø0.5 mm ø0.02" Opaque
Environmental resistance		Protective structure	IP64	IP64	IP67	-	-	IP67
		Ambient light	Incandescent lamp: 4000 lux max., Sunlight: 12000 lux max.					
		Ambient temperature/Relative humidity	-10 to +60°C (14 to +140°F) (No freezing)/35 to 85% RH (No condensation)					
Dimensions		[P.59]	[P.58]	[P.59]	[P.59]	[P.59]	[P.59]	[P.59]

*1 Depends on the mode, response time may be different even with the same detecting distance. Detecting distance in parentheses is a value when enabling the long distance detection mode with a 5 m sensor head cable.

*2 With thrubeam sensors, the smallest detectable object indicates the size of a detectable object from the maximum detecting distance.

Reflective sensor head

Type		Diffuse-reflective					Definite-reflective		
		General purpose			Environment-proof		General purpose		
		Long-detecting distance	Thin	Cylindrical	Long-detecting distance	Narrow-beam	Small spot	Long-detecting distance	
Model	PS-45	PS-46	PS-48	PS-205	PS-206	PS-47 (C)	PS-49 (C)		
Detecting distance*1 (mm inch)	MEGA	600 (900) 23.62" (35.43")	200 (250) 7.87" (9.84")	75 2.95"	600 (900) 23.62" (35.43")	250 9.84"	10±4 0.39"±0.16"	32 to 53 1.26" to 2.09"	
	ULTRA	400 (600) 15.75" (23.62")	150 (200) 5.91" (7.87")	45 1.77"	400 (600) 15.75" (23.62")	180 7.09"			
	SUPER	250 (450) 9.84" (17.72")	120 (160) 4.72" (6.30")	30 1.18"	250 (450) 9.84" (17.72")	100 3.94"			
	TURBO	200 (400) 7.87" (15.75")	100 (140) 3.94" (5.51")	25 0.98"	200 (400) 7.87" (15.75")	70 2.76"			
Light source		Infrared LED				Red LED			
Detectable object		Transparent and opaque							
Smallest detectable object*2		-	-	-	-	-	ø0.03 mm ø0.001" Copper wire	ø0.1 mm ø0.004" Copper wire	
Spot diameter		-	-	-	-	ø6 mm ø0.24" At detecting distance of 70 mm 2.76"	ø8 mm ø0.32" At detecting distance of 10 min 0.39"	ø1.5 mm ø0.06" At detecting distance of 50 min 1.97"	
Hysteresis (of detecting distance)		15% max.	10% max.	20% max.	15% max.			3% max.	
Environmental resistance		Protective structure	IP64	-	IP67			-	
		Ambient light	Incandescent lamp: 4000 lux max., Sunlight: 12000 lux max.					Incandescent lamp: 4000 lux max., Sunlight: 5000 lux max.	
		Ambient temperature	-10 to +60°C (14 to +140°F) (No freezing)					-10 to +50°C (14 to +122°F) (No freezing)	
		Relative humidity	35 to 85% RH (No condensation)						
Dimensions		[P.58]	[P.58]	[P.58]	[P.59]	[P.59]	[P.58]	[P.58]	

*1 Depends on the mode, response time may be different even with the same detecting distance. Detecting distance in parentheses is a value when enabling the long distance detection mode.

*2 With reflective sensors, the smallest detectable object was determined at the optimal detecting distance and sensitivity setting.

Options

Model number	Applicable model	Type
OP-2555	PS-55	Slit (detecting distance: 700 mm 27.56") (transmitter/receiver set)
OP-93672	PS-05	
OP-0162	PS-45 (accessory)	PS-45 mounting bracket set
OP-0230	PS-56, 52 (accessory)	Mounting nut set for PS-56
OP-2812	PS-55	Mounting bracket set for PS-55
OP-6349	PS-48 (accessory)	PS-48 mounting bracket
OP-6350	PS-58 (accessory)	PS-58 mounting bracket
OP-6800	PS2-61 (accessory)	PS2 mounting bracket
OP-7080	PS-201, 202 (accessory)	PS-201 mounting bracket (one side only)
OP-27934	Amplifier (accessory)	Connector for sensor head (2)
OP-42113	PS-55, 05, 52, 56, 58	Thrubeam transmitter side cable (20 m 65.6')
OP-42114	PS-55, 05, 52, 56, 58	Thrubeam receiver side cable (20 m 65.6')
OP-42115	PS-45, 46, 47, 49	Reflective (except PS-48) cable (20 m 65.6')
OP-42116	PS-201, 202	PFA thrubeam transmitter side cable (20 m 65.6')
OP-42117	PS-201, 202	PFA thrubeam receiver side cable (20 m 65.6')
OP-42118	PS-205, 206	PFA Reflective cable (20 m 65.6')

Amplifier

Cable type

Type	Appearance	Model		Control outputs	External input	Monitor output	Dimensions	
		NPN output	PNP output					
Standard	Main unit		PS-N11N NEW	PS-N11P NEW	1	1	0	[P.60]
	Expansion unit		PS-N12N NEW	PS-N12P NEW				

M8 connector type

Type	Appearance	Model		Control outputs	External input	Monitor output	Dimensions	
		NPN output	PNP output					
Standard	Main unit		PS-N11CN NEW	PS-N11CP NEW	1	1	0	[P.60]
	Expansion unit		PS-N12CN NEW	PS-N12CP NEW				

Zero line type

Type	Appearance	Model	Control outputs	External input	Monitor output	Dimensions
Standard		PS-N10 NEW	None*1	0	0	[P.60]

*1 Counted as one output when added to a NU Series communication unit.

Specifications

Type	Cable		M8 connector		Zero line
Main/Expansion unit	Main unit	Expansion unit	Main unit	Expansion unit	Expansion unit
Model	NPN PS-N11N	PS-N12N	PS-N11CN	PS-N12CN	PS-N10
I/O	Control outputs External input	1 output 1 input	None	1 input 1 output	1 input None
Response time	500 μs (TURBO)/1 ms (SUPER)/4 ms (ULTRA)/16 ms (MEGA)				
Output selection	LIGHT-ON/DARK-ON (switch-selectable)				
Timer function	Timer OFF/OFF-delay timer/ON-delay timer/One-shot timer, Timer duration selectable: 1 ms to 9999 ms, Maximum error against the setting value: ±10% max.				
Control outputs	NPN output	NPN open collector 30 V, (without expansion) 100 mA max., (with expansion) 20 mA max., residual voltage 1 V max. (when the out current is 10 mA or less)/2 V max. (when the output current is 10 to 100 mA)			
	PNP output	PNP open collector 30 V, (without expansion) 100 mA max., (with expansion) 20 mA max., residual voltage 1.2 V max. (when the output current is 10 mA or less)/2.2 V max. (when the output current is 10 to 100 mA)			
External input	Input time 2 ms (ON)/20 ms (OFF) or more*2				
Multiple connections to expansion units	Up to 17 main units can be connected				
Protection circuit	Reverse polarity protection, Over-current protection, Surge absorber				
Number of interference prevention units	4 for TURBO/SUPER/ULTRA/MEGA (When set to DOUBLE, the number of interference-prevention units will be doubled)				
Power voltage	24 VDC (operating voltage 10-30 VDC (with ripple)), ripple (P-P) 10% or less, Class 2 or LPS				
Power consumption	NPN	Normal: 810 mW or less (at 30V, 28 mA max. at 24 V, 34 mA max. at 12 V) Eco on mode: 700 mW or less (at 30V, 24 mA max. at 24 V, 27 mA max. at 12 V) Eco Full mode: 490 mW or less (at 30V, 17 mA max. at 24 V, 20 mA max. at 12 V)			
	PNP	Normal: 860 mW or less (at 30V, 30 mA max. at 24 V, 35 mA max. at 12 V) Eco on mode (ALL): 750 mW or less (at 30V, 26 mA max. at 24 V, 28 mA max. at 12 V) Eco Full mode: 540 mW or less (at 30V, 19 mA max. at 24 V, 21 mA max. at 12 V)			
Environmental resistance	Ambient temperature	-20°C to +55°C (-4°F to +131°F) (No freezing)*3			
	Relative humidity	35 to 85% RH, (No condensation)			
	Vibration resistance	10 to 55 Hz, double amplitude: 1.5 mm 0.06", 2 hours each in the X, Y and Z axis			
	Shock resistance	500 m/s ² 3 times for each of X, Y and Z axis			
Material	Case	Main unit and cover material: Polycarbonate			
	Cable	PVC			
Case size	H 32.6 mm 1.28" x W 9.8 mm 0.39" x L 78.7 mm 3.1"				
Weight	Approx. 75 g	Approx. 65 g	Approx. 20 g	Approx. 20 g	Approx. 20 g

*1 Counted as one output when added to a NU Series communication unit. *2 Input time is 25 ms (ON)/25 ms (OFF) when the external calibration time is selected.

*3 If more than one unit is used together, the ambient temperature varies with the conditions below. Mount the units on the DIN rail with mounting brackets and check that the output current is 20 mA or less for a unit.
One or two more units connected: -20°C to +55°C (-4°F to +131°F); 3 to 10 more units connected: -20°C to +50°C (-4°F to +122°F); 11 to 16 more units connected: -20°C to +45°C (-4°F to +113°F).

I/O Circuit Diagram

Cable type

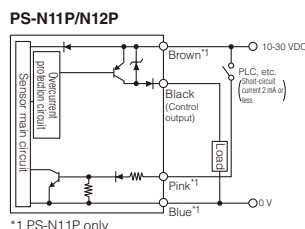
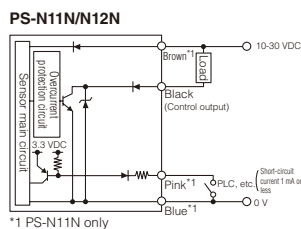

M8 connector type

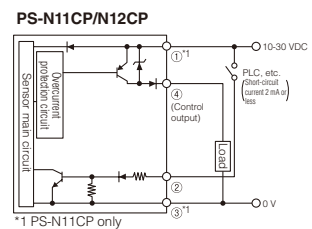
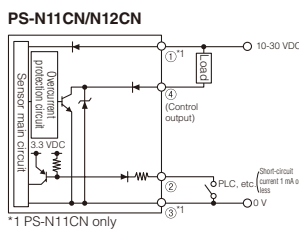

PS-52 (C)

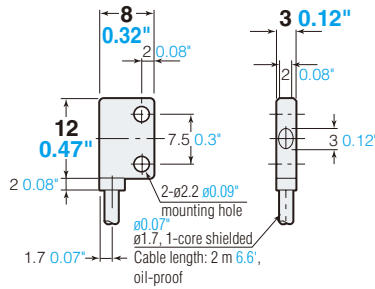

Accessory
Screws (M2×10), 4 pieces
Nut, spring washer, flat washer: 4 each

PS-55 (C)

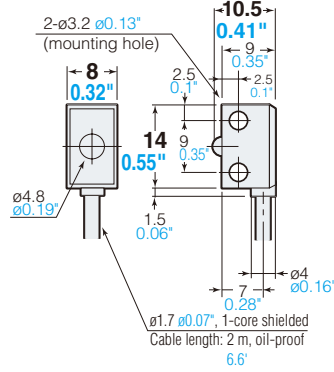

With PS-55 (C) slit attached (option OP-2555)

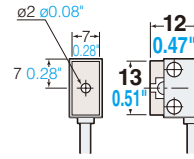

PS-56

Receiver

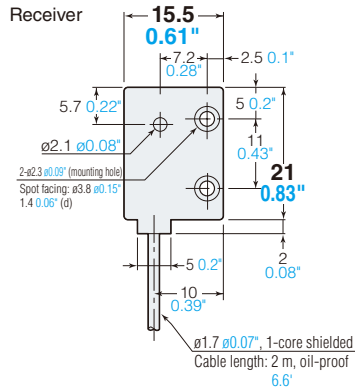

Accessory
Screws (M2×10), 4 pieces
Nut, spring washer, flat washer: 4 each

Transmitter

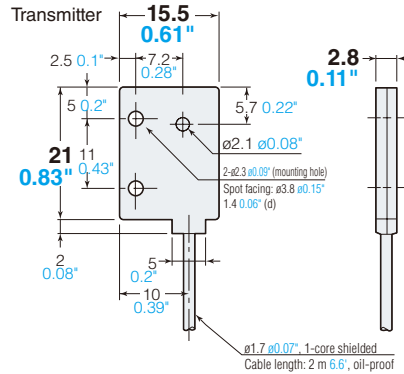

PS-58

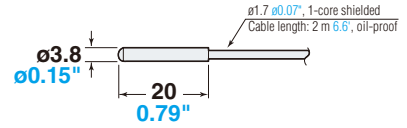

Mounting bracket (accessory) for PS-58
(option for one side only: OP-6350)

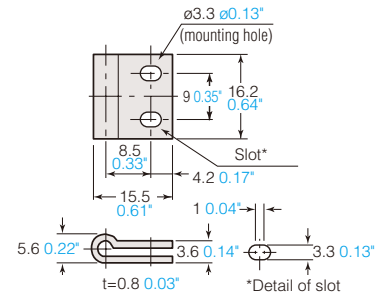

PS-201 (C)/PS-202

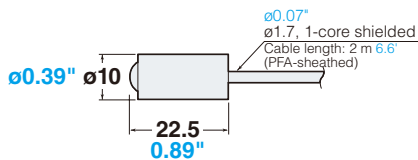

Mounting bracket (accessory)
for PS-201 (C)/PS-202
(option for one side only: OP-7080)

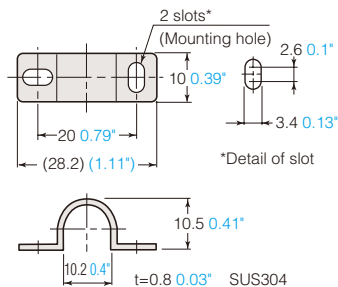

PS-205

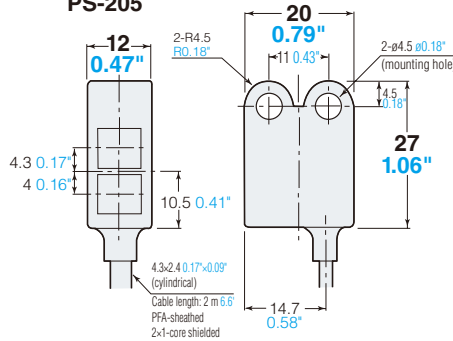

PS-206

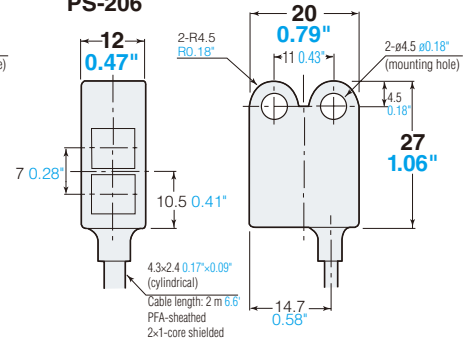

Unit : mm inch

PS-N11N/N11P Cable type, Main unit

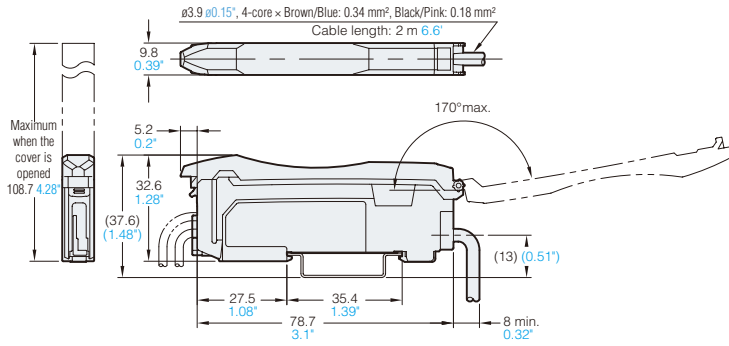

PS-N12N/N12P Cable type, Expansion unit

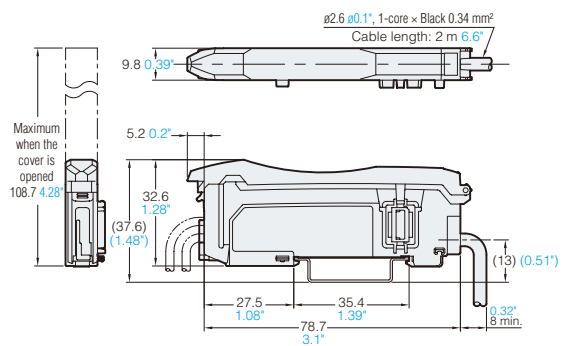

PS-N11CN/N11CP M8 connector type, Main unit

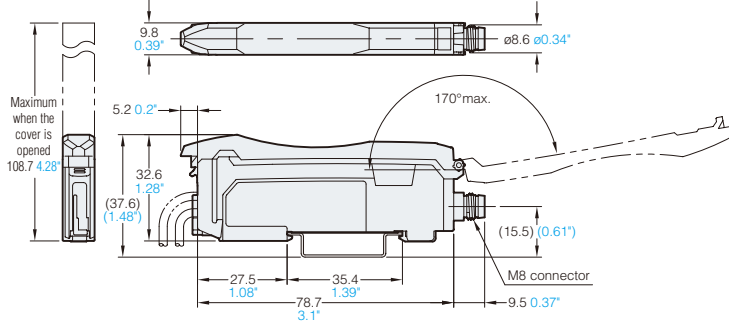

PS-N12CN/N12CP M8 connector type, Expansion unit

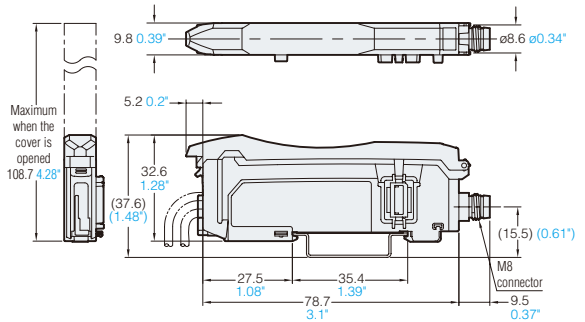

M8 connector cable (**OP-73864 / 73865** sold separately)

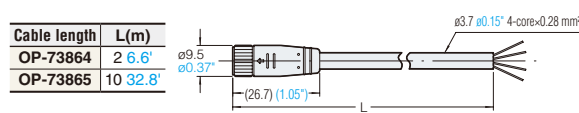

M8 connector junction cable (**OP-85498** sold separately)

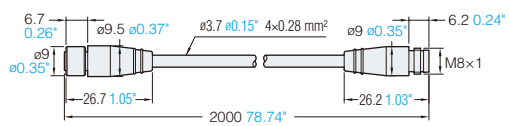

PS-N10 Zero line type, Expansion unit

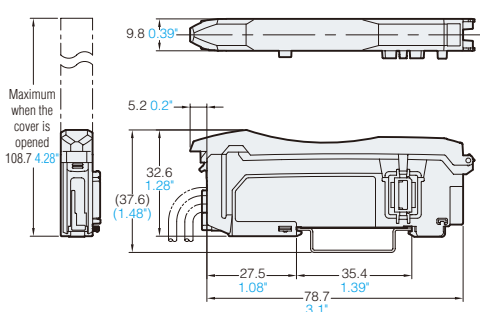

OP-87199 Conversion adaptor



When the end unit is attached (**OP-26751** sold separately)

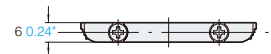

DIN-rail mounting

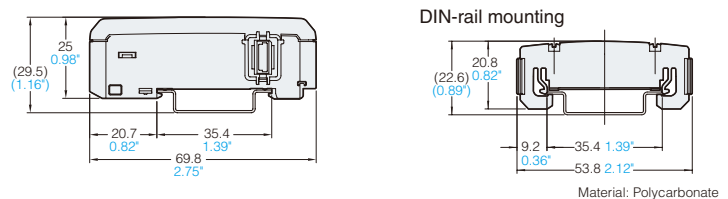

Common for all types

When several units are connected:

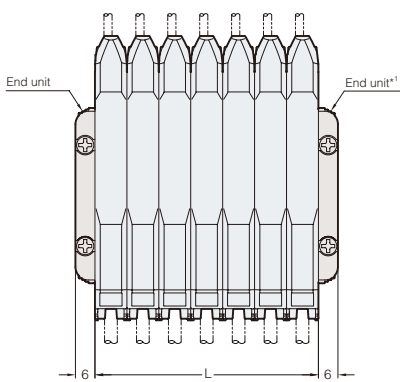

No. of units	L (mm inch)
1	9.8 0.39"
2	19.6 0.77"
3	29.4 1.16"
4	39.2 1.54"
5	49.0 1.93"
6	58.8 2.32"
7	68.6 2.7"
8	78.4 3.09"
9	88.2 3.47"
10	98.0 3.86"
11	107.8 4.24"
12	117.6 4.63"
13	127.4 5.02"
14	137.2 5.4"
15	147.0 5.79"
16	156.8 6.17"
17	166.6 6.56"

*1 End units must be used when several units are connected.(OP-26751)

When the mounting bracket is attached (**OP-73880** sold separately)

Cable type

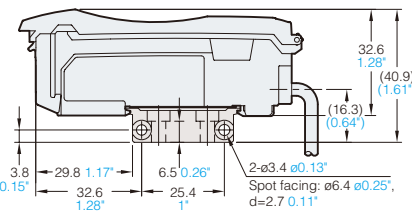

Reverse side of mounting bracket

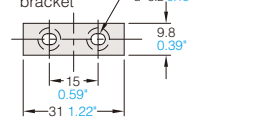

M8 connector type

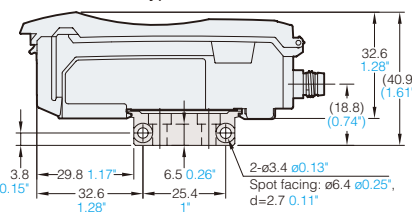

Common options for LV-NEO/FS-NEO/PS-NEO

Type	Appearance	Description	Model	Dimensions
Amplifier securing bracket (for main unit)		Can be installed without a DIN-rail. Can be installed from above or side as shown in right. 	OP-73880	[P.23]
End unit (when using expansion units)	 2 per set	Used to secure the main and expansion units. 	OP-26751	[P.23]
M8 connector cable (2 m 6.6' / 10 m 32.8')		Used to connect to the M8 connector type amplifier (model numbers end with a "CN" or "CP"). Connector cables are not included with the amplifier. 	2 m 6.6' type OP-73864	[P.23]
			10 m 32.8' type OP-73865	
M8 connector junction cable (2 m 6.6')		Used to extend the M8 connector cable.	OP-85498	[P.23]
Expansion Converter Unit		The LV-NEO / FS-NEO / PS-NEO Series has different amplifier connectors than the FS-V30, LV, and CZ series. This is an adapter to connect these models. It supplies power from the main unit to the expansion unit and prevents interference. *Communication is not supported.	OP-87199	[P.23]

Incorporate the NEO Series with an open field network for complete interfacing versatility



CC-Link Network Communication unit
NU-CL1



DeviceNet Network Communication unit
NU-DN1



EtherNet/IP Network Communication unit
NU-EP1



EtherCAT Network Communication unit
NU-EC1



In addition to saving space and achieving a dramatic reduction in wiring, the remote management of multiple sensors significantly improves convenience and functionality.

Compatible with multiple open field networks

KEYENCE has developed 4 communication units that are compatible with open field networks (CC-Link, DeviceNet, EtherNet/IP, EtherCAT). These units enable the NEO Series sensors to be installed and used on the same network as a variety of devices from other manufacturers.

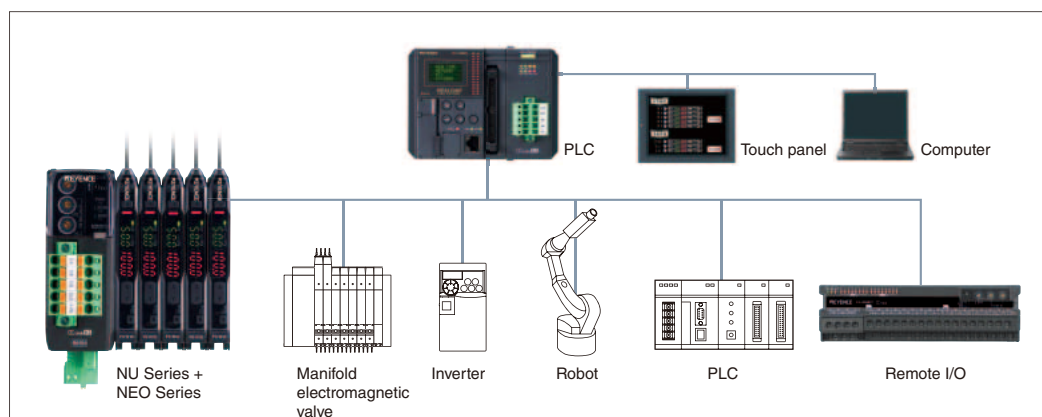

Dramatic reduction in wiring and installation time

Only a single communication cable is required between the PC/PLC ↔ and the NU Series for wiring. This achieves a dramatic reduction in wiring and saves a significant amount of space. In addition, wiring work that conventionally requires a great deal of time and effort has been greatly reduced.

Reduced production costs by introducing the NU Series



- ▶ No need for a complicated cable layout
- ▶ No need to trim the cables
- ▶ No additional wiring required when replacing sensors
- ▶ No need for a terminal block



Multiple sensors can be simultaneously managed

By utilizing the network, multiple sensors that exist on the same line can be simultaneously managed, significantly increasing convenience and ease-of-use in the field.

The status of the sensors can be monitored and settings for all of the sensors can be modified together from a touch panel or computer.

Monitoring	Product change	Sensor status log
<Conventional>	<Conventional>	<Conventional>
I want to check on the sensors before a detection error stops production, but it is too troublesome to go and look at each individual sensor....	Because multiple products are manufactured on the same line, settings need to be adjusted frequently, but it is time consuming to have to adjust each individual sensor every time...	A sensor malfunction has occurred and I want to check it, but it doesn't seem to reoccur... I cannot waste time just watching and waiting.
▼	▼	▼
<NU Series>	<NU Series>	<NU Series>
Easy monitoring from the display!	Product change with the push of a button!	Troubleshooting made easy!
The sensor status can be monitored on an HMI, PLC, or PC, making it easier to detect problems before an error occurs.	The NU allows for settings to be changed externally from an HMI, PLC, or PC. As a result, changeover time can be reduced, even where sensor settings must be changed frequently.	If sensor information (light intensity/ setting values/error output) is stored in the log, the cause of minor errors is easily identified.
		

New lineup of sensor input units





The e-CON connection unit can be used for sensors, electromagnetic valves, and cylinder switches other than the NEO Series models. The ON/OFF status can be displayed and checked on a touch panel or computer.



e-CON Network Communication Input Unit
NU-EN8N

Lineup

Open Field Network Units

Type	Appearance	Network	Model	Dimensions
Communication unit		CC-Link	NU-CL1	[P.66]
		DeviceNet	NU-DN1	
		EtherNet/IP	NU-EP1	
		EtherCAT	NU-EC1	
e-CON Input unit		-	NU-EN8N	

Option

Model	Type
OP-79426	Ver.1.10 compatible CC-Link dedicated 20 m 65.6' cable
OP-79427	Ver.1.10 compatible CC-Link dedicated 100 m 328.1' cable
OP-51504	STP (Shielded twisted pair) 0.2 m 0.7' cable
OP-51505	STP (Shielded twisted pair) 0.5 m 1.6' cable
OP-51506	STP (Shielded twisted pair) 1 m 3.3' cable
OP-51507	STP (Shielded twisted pair) 3 m 9.8' cable
OP-51508	STP (Shielded twisted pair) 5 m 16.4' cable
OP-51509	STP (Shielded twisted pair) 10 m 32.8' cable
OP-84338*1	e-CON connector (2 per set)

*1 Use shield outer diameter 1.15 to 1.35 mm **0.05" to 0.05"**, wire range 0.1 to 0.5 mm² cable.
Prepare separate e-CON connectors capable of fitting the necessary cable diameter when the cable diameter is outside the OP-84338 specification listed above.

Specifications

CC-Link compatible communication unit: NU-CL1

Model	NU-CL1	
CC-Link Specifications	Compatible version	Ver.2.00/Ver.1.10 (switchable)
	Number of occupied stations	Ver.2.00: 3 stations, Ver.1.10: 1/2/3/4 stations (switchable)
	Type of station	Remote device station
	Transmission speed	156 kbps/625 kbps/2.5 Mbps/5 Mbps/10 Mbps
	Setting of station numbers	1 to 64
Sensor connection specifications	Connectable sensors	Sensor amplifiers with N-bus support*1
	Number of connectable sensor units	Up to 16 units *2
	Power supply	Power is supplied from the unit via a wiring-saving connector.
	Maximum passing current	Total 1200 mA max.*3
Power voltage	24 VDC±10%, ripple (p-p) 10% or less	
Power consumption	1400 mW or less (55 mA max. at 24 V)*4	
Weight (including connector)	Approx. 80 g	
Accessory	Instruction manual, CC-Link connector, power connection connector, termination resistor, end unit × 2	

*1 "N-bus" is the name of KEYENCE's wiring-saving system for sensor amplifiers. *2 Depends on the sensor amplifiers connected.

*3 Value for the current which can be supplied to this product or a sensor amplifier unit connected to this product. *4 Current to be supplied to the connected sensor amplifier is not included.

DeviceNet compatible communication unit: NU-DN1

Model	NU-DN1			
DeviceNet Specifications	Supported functions	I/O Message (polling), Explicit Message		
	Address setting	0 to 63 (PGM compatible)		
	Baud rate (automatically switched)	500 kbps	250 kbps	125 kbps
	Maximum cable length	100 m 328.1' (thick cable) 100 m 328.1' (thin cable)	250 m 820.2' (thick cable) 100 m 328.1' (thin cable)	500 m 1640.4' (thick cable) 100 m 328.1' (thin cable)
Sensor connection specifications	Connectable sensors	Sensor amplifiers with N-bus support*1		
	Number of connectable sensor units	Up to 16 units *2		
	Power supply	Power is supplied from the DeviceNet communication power supply via the unit.		
	Maximum passing current	Total 1200 mA max.*3		
Power voltage	11 to 25 VDC			
Power consumption	1480 mW or less (60 mA max. at 24 V, 106 mA max. at 12 V)*4			
Weight (including connector)	Approx. 65 g			
Accessory	Instruction manual, DeviceNet connector, end unit × 2			

*1 "N-bus" is the name of KEYENCE's wiring-saving system for sensor amplifiers. *2 Depends on the sensor amplifiers connected.

*3 Value for the current which can be supplied to this product or a sensor amplifier unit connected to this product. *4 Current to be supplied to the connected sensor amplifier is not included.

EtherNet/IP compatible communication unit: NU-EP1

Model		NU-EP1
Ethernet specifications	Compliance	IEEE802.3 (10BASE-T) IEEE802.3u (100BASE-TX) IEEE802.3af (Power over Ethernet, Class3)
	Transmission rate	10 Mbps (10BASE-T) 100 Mbps (100BASE-TX)
	Transmission media	STP cable or category 3 or higher UTP cable (10BASE-T) ^{*1} STP cable or category 5 or higher UTP cable (100BASE-TX)
	Maximum cable length	100 m 328.1' (distance between the unit and Ethernet switch)
	Maximum number of connectable hubs ^{*2}	4 (10BASE-T) 2 (100BASE-TX)
Ethernet/IP Specifications	Compatible functions	Cyclic communication Compatible with UCMM and Class3 messaging (Explicit messaging)
	Number of connections	64
	RPI (transmission cycle)	0.5 to 10000 ms (in units of 0.5 ms)
	Tolerable communication bandwidth for Cyclic communication	6000 pps
	Conformance test	Compatible with Version A7
Sensor connection specifications	Connectable sensors	Sensor amplifiers with N-bus support ^{*3}
	Number of connectable sensor units	Up to 16 units ^{*4}
	Power supply	Power is supplied from the unit via a sensor amplifier connection connector.
	Allowable passing current ^{*5}	Total 1200 mA max.
	Power during PoE power receiving ^{*6}	Supply voltage: 24 V±10%, supply current: 360 mA or less ^{*7}
Power voltage	24 VDC±10%, ripple (p-p) 10% or less (with power supply connector) 48 VDC (Max.57 VDC) (During PoE power receiving)	
Power consumption	1500 mW or less (60 mA max. at 24 V) ^{*8}	
Weight (including connector)	Approx. 80 g	
Accessory	Instruction manual, power connector, 2 end units	

* Cannot connect to the following KEYENCE's PoE power supply devices: [DT-100A], [DT-500], [NE-V08]

*1 When using the power PoE power receiving function, use the STP cable or Category 5 or higher UTP cable. *2 The number of connectable units is not limited when using a switch.

*3 "N-bus" is the name of KEYENCE's wiring-saving system for sensor amplifiers. *4 Depends on the sensor amplifiers connected. *5 Value for the current which can be supplied to this unit or to a sensor amplifier unit connected to this unit. *6 Power which can be supplied to the sensor amplifier when using the PoE power receiving function. *7 Varies according to the working ambient temperature. (-20 to 45°C (-4 to 113°F): 360 mA or less, 45 to 50°C (113 to 122°F): 260 mA or less, 50 to 55°C (122 to 131°F): 140 mA or less) *8 Current to be supplied to the connected sensor amplifier is not included.

EtherCAT compatible communication unit: NU-EC1

Model		NU-EC1
Ethernet specifications	Compliance	IEEE802.3u (100BASE-TX)
	Transmission rate	100 Mbps (100BASE-TX)
	Transmission media	Category 5e or higher STP cable
	Distance between nodes	100 m 328.1'
	Communication port	RJ-45 × 2
EtherCAT communication specifications	Compatible functions	Process data object communication (cyclic communication) Mailbox communication (message communication) CoE compatible
Sensor connection specifications	Connectable sensors	Sensor amplifiers with N-bus support ^{*1}
	Number of connectable sensor units	Up to 16 units ^{*2}
	Power supply	Power is supplied from the unit via a wiring-saving connector
	Allowable passing current ^{*3}	Total 1200 mA max.
Power voltage	24 VDC±10%, ripple (p-p) 10% or less	
Power consumption	1700 mW or less (70 mA max. at 24 V) ^{*4}	
Weight (including connector)	Approx. 80 g	
Accessory	Instruction manual, power connector, 2 end units	

* EtherCAT is a registered trade name of BECKHOFF.

*1 "N-bus" is the name of KEYENCE's wiring-saving system for sensor amplifiers. *2 Depends on the sensor amplifiers connected.

*3 Value for the current which can be supplied to this product or a sensor amplifier unit connected to this product. *4 Current to be supplied to the connected sensor amplifier is not included.

Communication unit compatible e-CON network input unit: NU-EN8N

Model		NU-EN8N
Connectable communication unit		NU-CL1, NU-DN1, NU-EP1, NU-EC1
Number of connectable sensor units		Up to 2 units (occupied ID number: 8) ^{*1}
I/O	Connector	e-CON connector (4 pin)
	Inputs	8
	Supply voltage for equipment	Supplied from the communication unit
	Supply current	520 mA or less (total for 8 ports)
	Input signal	NPN open collector output, contact output
	Input response time	20 μs or less
	Internal input voltage	8 VDC (Reference value of input current: 3.1 mA)
	Input resistance	2.4 kΩ
Power voltage	12 to 24 VDC, ripple (p-p) 10% or less ^{*2}	
Weight (including tag)	Approx. 55 g	
Accessory	Instruction manual, tag, index seal	

*1 To connect the NU-EN8N to a communication unit, connect it after the sensor amplifier. Sensor amplifier connected after this unit will not be recognized by the communication unit.

*2 Power to the NU-EN8N is supplied from the connected communication unit.

NU-CL1

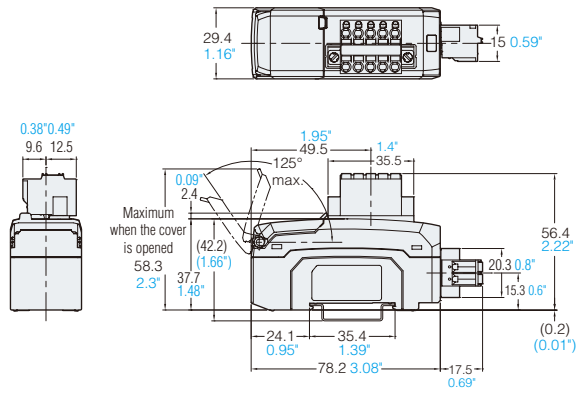

NU-DN1

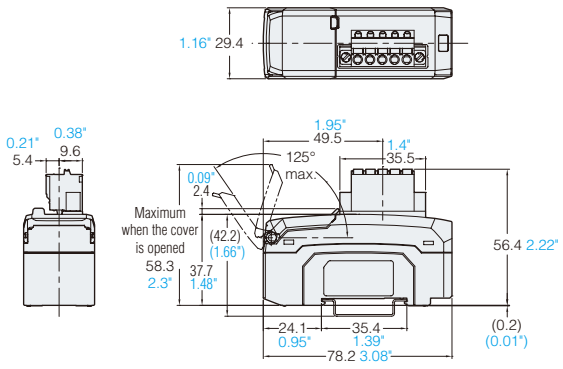

NU-EP1

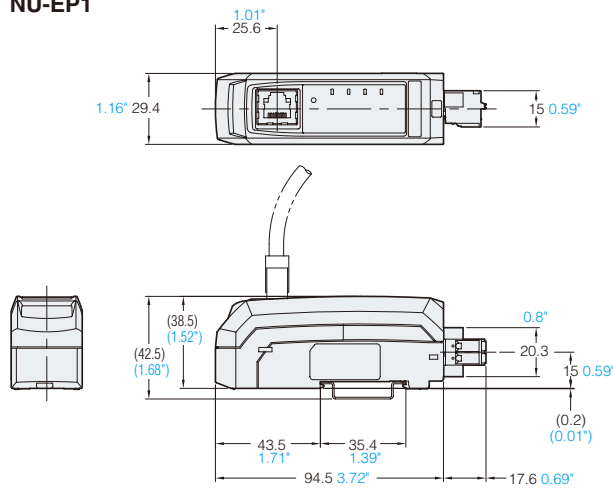

NU-EC1

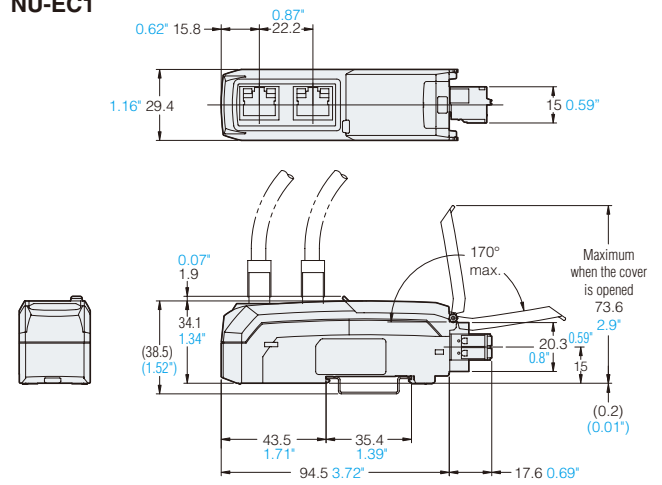

NU-EN8N

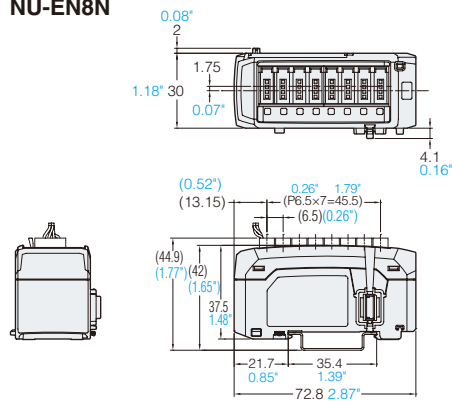

When the tag (supplied with NU-EN8N) is attached.

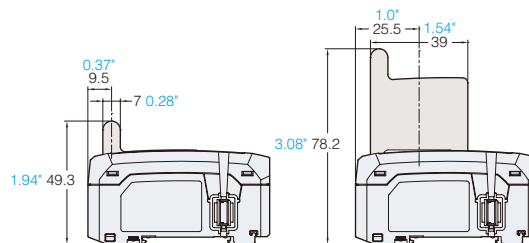

< Considerations when using the NEO Series >



To replace the LV Series with the LV-N Series

When you replace your LV-Hxx sensor head with the LV-N Series, be aware of the following:

- (1) The LV-N Series sensor heads must be used with the LV-N Series amplifiers.
- (2) If the desired LV sensor head is not available with the LV-N Series, you must use the LV-H Series amplifier.

Type	LV Series sensor head	LV-N Series sensor head	Remarks
Diffuse-reflective	LV-H32	LV-NH32 NEW	-
	LV-H35	LV-NH35 NEW	-
	LV-H35F	-	Use LV-21A(P) / 22A(P) for an amplifier.
	LV-H37	LV-NH37 NEW	-
	LV-H41	-	Use LV-11A for an amplifier.
	LV-H42	LV-NH42 NEW	-
Retro-reflective Type	LV-H47	-	Use LV-21A(P) / 22A(P) for an amplifier.
	LV-H62	LV-NH62 NEW	-
	LV-H62F	-	Use LV-21A(P) / 22A(P) for an amplifier.
	LV-H64		
	LV-H65		
LV-H67			
Thru-beam type	LV-H100	LV-NH100 NEW	-
	LV-H110	LV-NH110 NEW	
	LV-H300	LV-NH300 NEW	

* All sensor head LV-Sxx can be used with the LV-N Series amplifiers.

Type		Appearance	Model		Control outputs	Calibration external input	Laser transmission stop input	Monitor output
			NPN output	PNP output				
For reflective/retro-reflective	Main unit		LV-21A	LV-21AP	2	1	1	0
	Expansion unit		LV-22A	LV-22AP	2	0	0	0
For infrared LV-H41	Main unit		LV-11A	-	2	1	1	0
Thru-beam type	Main unit		LV-51M	LV-51MP	2	0	1	1
	Expansion unit		LV-52	LV-52P	2	0	0	0

Number of connectable amplifiers

To expand the LV-N, FS-N, or PS-N Series, up to 16 expansion units and 1 main unit can be connected. Therefore up to 17 total units can be connected. However, be aware that the number of connectable units is dependent upon the number of control outputs for each amplifier.

Series	Model	Number of control outputs
LV-N	LV-N11N (P) / N12N (P)	2
	Others	1
FS-N	FS-N13x/N14x	2
	Others	1
PS-N	All models	1

Number of mutual interference prevention units

When the NEO Series main and expansion units are connected, the mutual interference prevention function enables the following number of units to closely operate without interference with respect to each power mode.

Power mode		HSP	FINE	TURBO	SUPER	ULTRA	MEGA
LV-N10	Normal	x	2	2 ^{*2}	2 ^{*2}	4	4
	DOUBLE ^{*1}	x	4	4 ^{*2}	4 ^{*2}	8	8
FS-N10	Normal	x	4	8	8	8	8
	DOUBLE ^{*1}	x	8	16	16	16	16
PS-N10	Normal	-	-	4	4	4	4
	DOUBLE ^{*1}	-	-	8	8	8	8

(This depends on the Series with the smallest number of units, when LV-N, FS-N, and PS-N are mixed in a system.)

*1 Can be switched to DOUBLE mode by the amplifier mode setting. When DOUBLE mode is used, all connected amplifiers must be in DOUBLE mode.

*2 The number of units is 4 in normal mode and 8 in DOUBLE mode when connected to the LV-S31.

neo series



**CALL
TOLL
FREE**

TO CONTACT YOUR LOCAL OFFICE
1-888-KEYENCE
1 - 8 8 8 - 5 3 9 - 3 6 2 3

www.keyence.com



SAFETY INFORMATION

Please read the instruction manual carefully in order to safely operate any KEYENCE product.

KEYENCE CORPORATION OF AMERICA

Corporate Office 669 River Drive, Suite 403, Elmwood Park, NJ 07407 PHONE: 201-930-0100 FAX: 201-930-0099 E-mail: keyence@keyence.com
Sales & Marketing Head Office 1100 North Arlington Heights Road, Suite 350, Itasca, IL 60143 PHONE: 888-539-3623 FAX: 630-285-1316

■ Regional offices	CO Denver	IN Indianapolis	MI Detroit	NJ Elmwood Park	OH Cincinnati	SC Greenville	TX Dallas
AL Birmingham	FL Tampa	KS Kansas City	MI Grand Rapids	NY Rochester	OH Cleveland	TN Knoxville	VA Richmond
CA N. California	GA Atlanta	KY Louisville	MN Minneapolis	NC Charlotte	OR Portland	TN Nashville	WA Seattle
CA Los Angeles	IL Chicago	MA Boston	MO St. Louis	NC Raleigh	PA Philadelphia	TX Austin	WI Milwaukee

KEYENCE CANADA INC.

Head Office PHONE: 905-696-9970 FAX: 905-696-8340 E-mail: keyencecanada@keyence.com
Montreal PHONE: 514-694-4740 FAX: 514-694-3206

KEYENCE MEXICO S.A. DE C.V.

PHONE: +52-81-8220-7900 FAX: +52-81-8220-9097
E-mail: keyencemexico@keyence.com

KEYENCE CORPORATION

1-3-14, Higashi-Nakajima, Higashi-Yodogawa-ku, Osaka, 533-8555, Japan PHONE: +81-6-6379-2211

The information in this publication is based on KEYENCE's internal research/evaluation at the time of release and is subject to change without notice.
Copyright (c) 2011 KEYENCE CORPORATION. All rights reserved. LVNeo-KA-GC-E 1081-4 [611516] Printed in Japan



KA1-1061